

Ampco Centrifugal Pumps

DATA SHEET

MODEL LM-R01 40 x 40

MODEL LM-R02 40 x 40

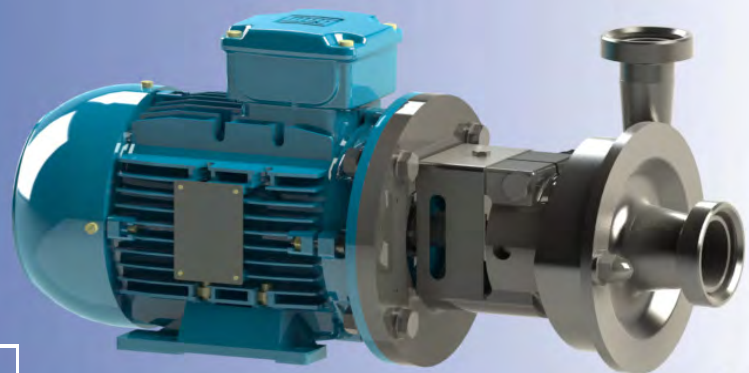

CE

Connections DIN 11851 thread

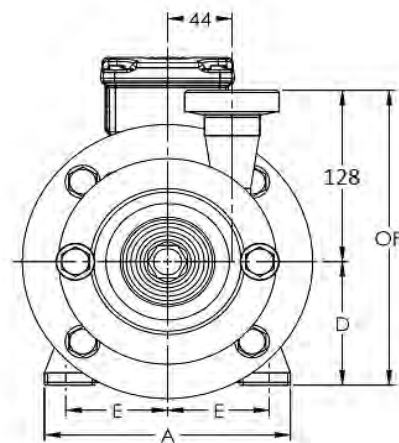
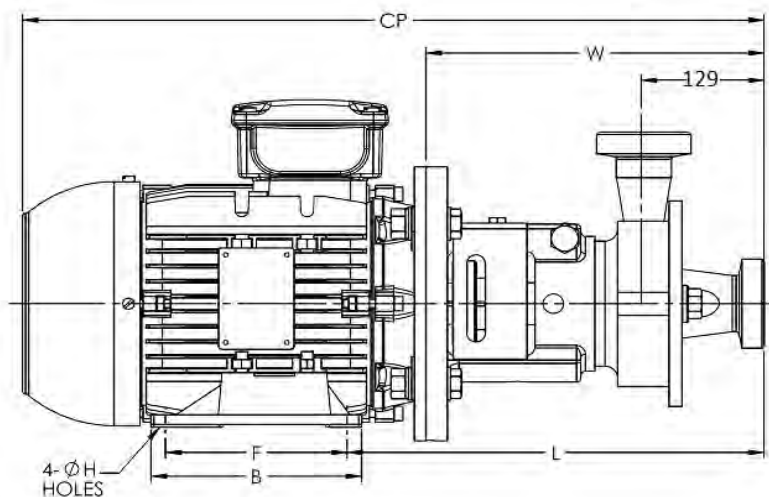

TEFC MOTOR			DIMENSIONS IN MILLIMETERS							(All Values For Reference Only) <small>Data subject to change without notice.</small>			MASS
kW	RPM	FRAME	A (typ)	B (typ)	D	E	F	ØH	L	W	CP	OP	Kg
0.75kW	1450	80	149	125.5	80	62.5	100	10	283	233	470	205	23
0.75kW	2900	80	149	125.5	80	62.5	100	10	283	233	470	205	22

MATERIAL SPECIFICATIONS

PART NAME	STAINLESS STEEL
Casing, Cover & Impeller	316L Stainless
Stub Shaft	316L Stainless
Adapter	304 Stainless

PUMP CURVES

MODEL LM-R01 40 x 40
MODEL LM-R02 40 x 40

Ampco Centrifugal Pumps

Curves show approximate characteristics based on clear 20°C water. Rated point is guaranteed

LM-Series pumps have standard stainless steel adapters and silicon carbide vs. carbon seals.

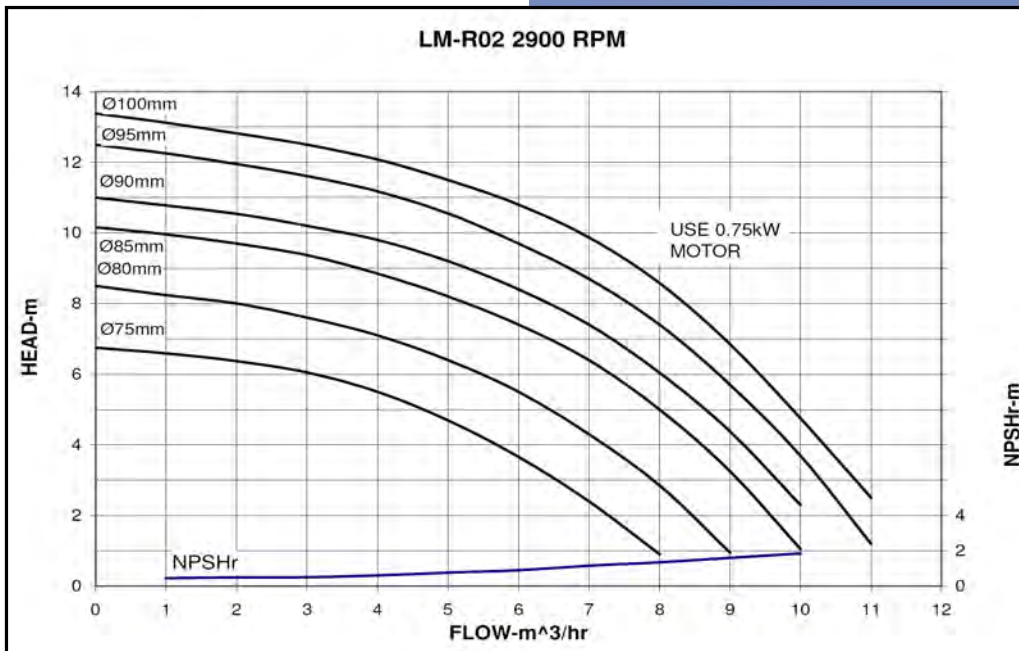
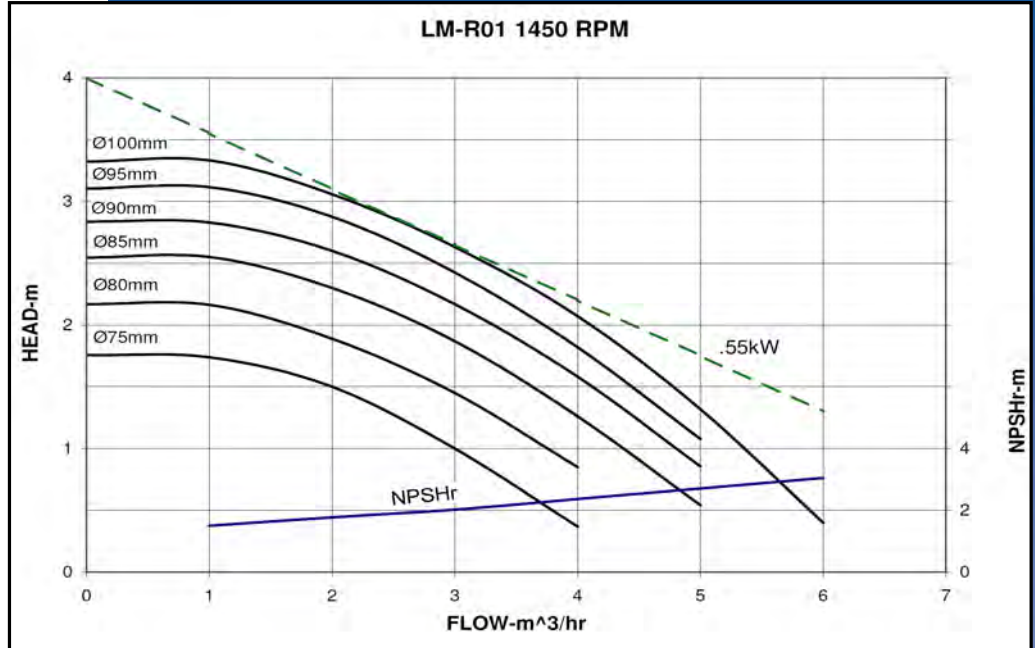

LM pumps are in conformance with 3A sanitary standards for centrifugal and positive rotary pumps for milk and milk products, Number 02-10.

LM-Series pumps have a standard 0.8µm (micrometers) finish, on all product contact surfaces.

Ampco Pumps Company

2045 West Mill Road
Glendale, Wisconsin 53209
PHONE (414) 643-1852
FAX (414) 643-4452

LM-R01/R02 40X40 01/11

Ampco Centrifugal Pumps

DATA SHEET

MODEL LM-R11 50 x 40

MODEL LM-R12 50 x 40

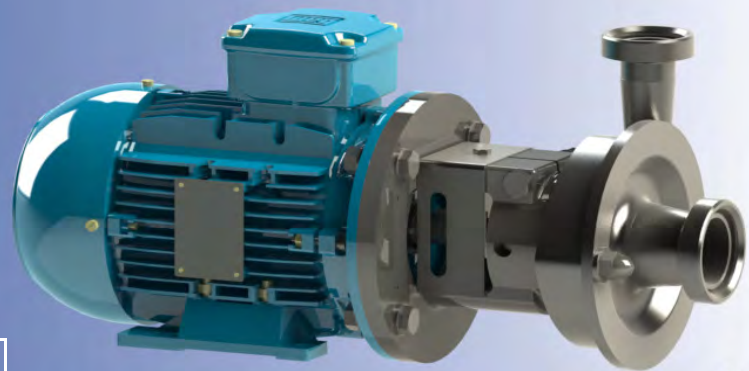

CE

Connections DIN 11851 thread

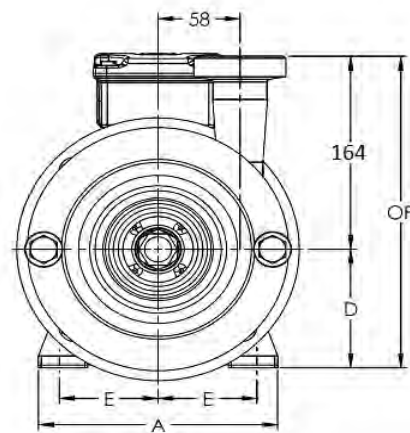
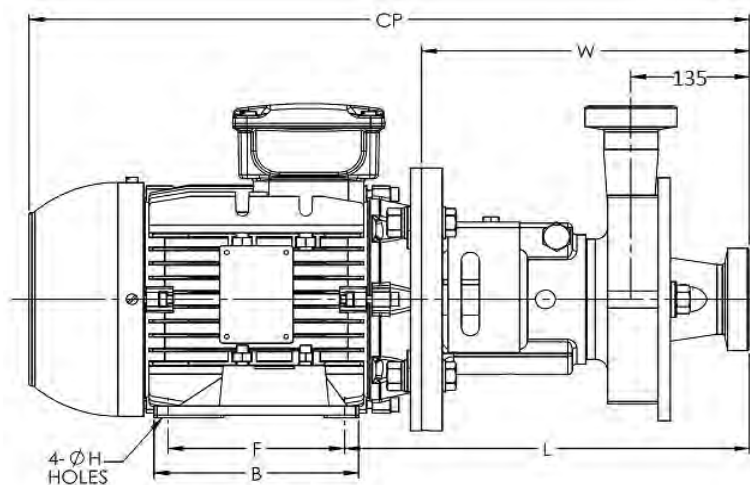

TEFC MOTOR			DIMENSIONS IN MILLIMETERS							(All Values For Reference Only) <small>Data subject to change without notice.</small>			MASS
kW	RPM	FRAME	A (typ)	B (typ)	D	E	F	ØH	L	W	CP	OP	Kg
0.75kW	1450	80	149	125.5	80	62.5	100	10	283	233	470	205	26
0.75kW	2900	80	149	125.5	80	62.5	100	10	283	233	470	205	24
1.1kW	2900	80	149	125.5	80	62.5	100	10	283	233	470	205	24
1.5kW	2900	90S	164	145	90	70	100	10	287	231	509	237	30
2.2kW	2900	90L	164	145	90	70	125	10	287	231	509	237	30
3kW	2900	100L	188	170	100	80	140	12	318	255	571	247	43

MATERIAL SPECIFICATIONS

PART NAME	STAINLESS STEEL
Casing, Cover & Impeller	316L Stainless
Stub Shaft	316L Stainless
Adapter	304 Stainless

PUMP CURVES

MODEL LM-R11 50 x 40
MODEL LM-R12 50 x 40

Ampco Centrifugal Pumps

Curves show approximate characteristics based on clear 20°C water. Rated point is guaranteed

LM-Series pumps have standard stainless steel adapters and silicon carbide vs. carbon seals.

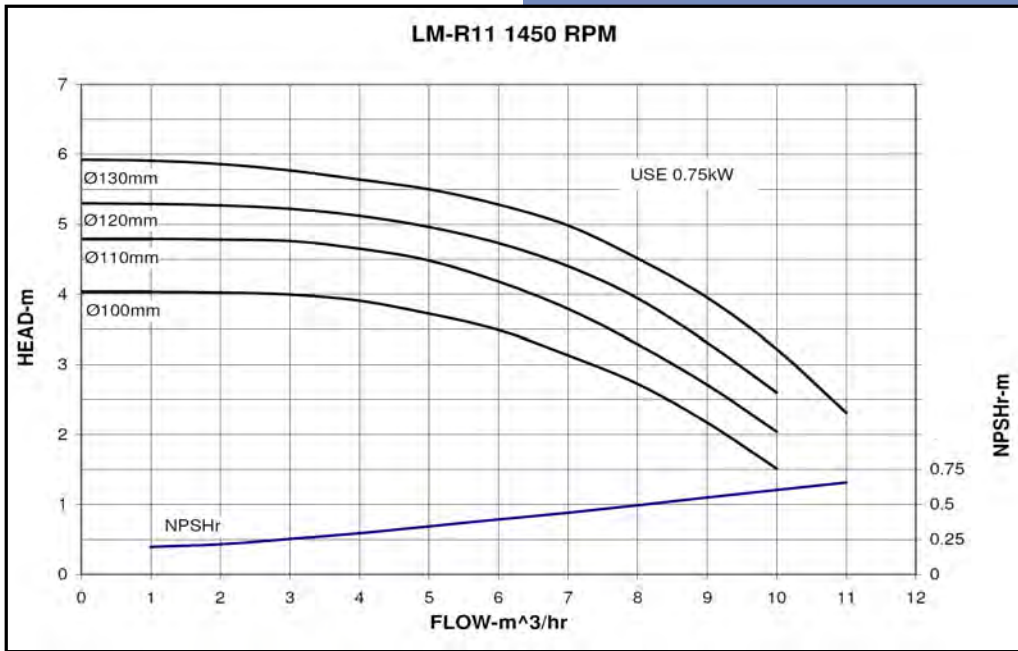
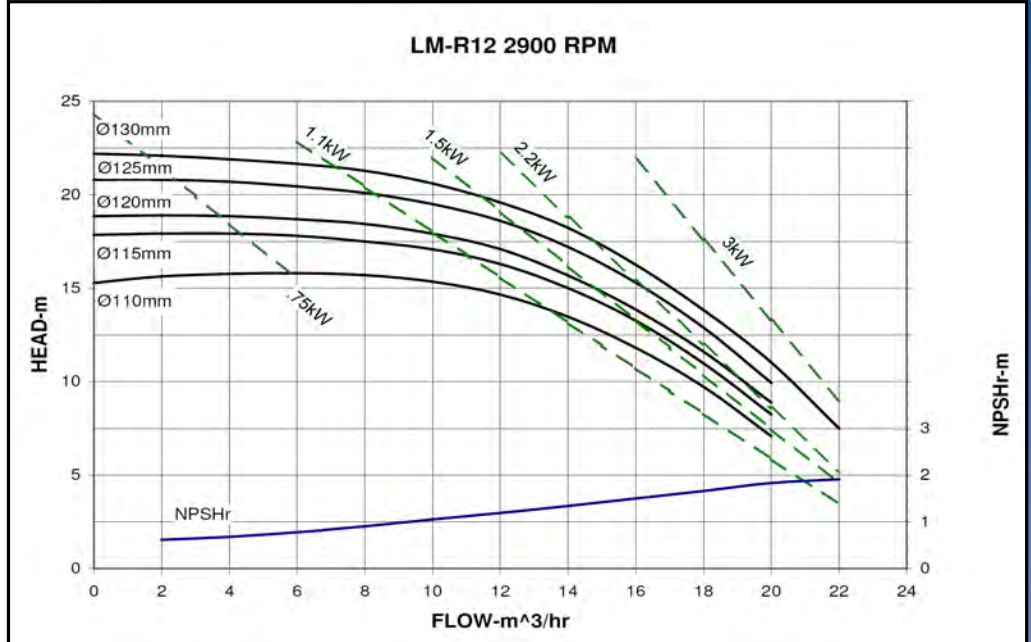

LM pumps are in conformance with 3A sanitary standards for centrifugal and positive rotary pumps for milk and milk products, Number 02-10.

LM-Series pumps have a standard 0.8µm (micrometers) finish, on all product contact surfaces.

Ampco Pumps Company

2045 West Mill Road
 Glendale, Wisconsin 53209
 PHONE (414) 643-1852
 FAX (414) 643-4452

LM-R11/R12 50X40 01/11

Ampco Centrifugal Pumps

DATA SHEET

MODEL LM-R21 50 x 40

MODEL LM-R22 50 x 40

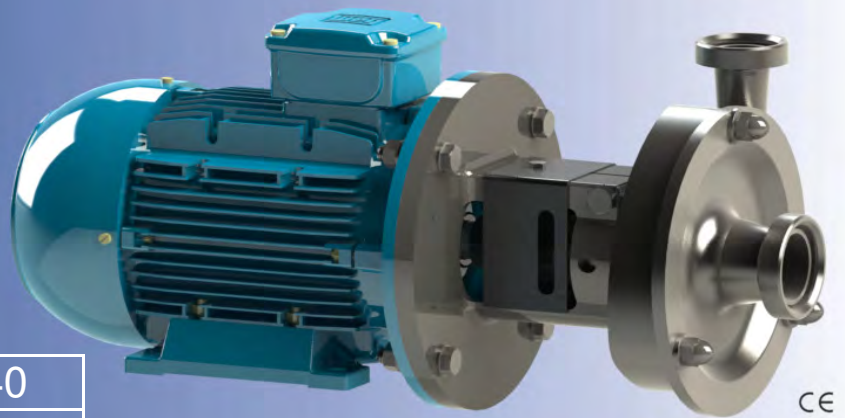

Connections DIN 11851 thread

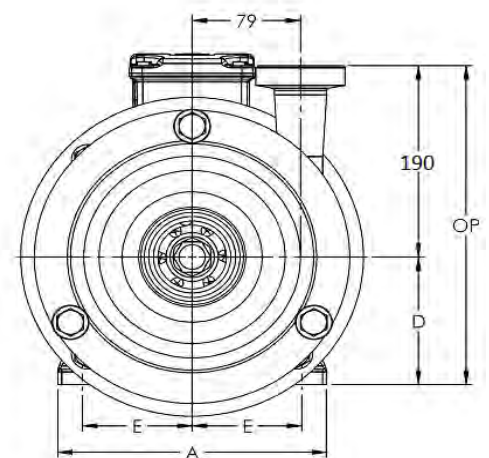
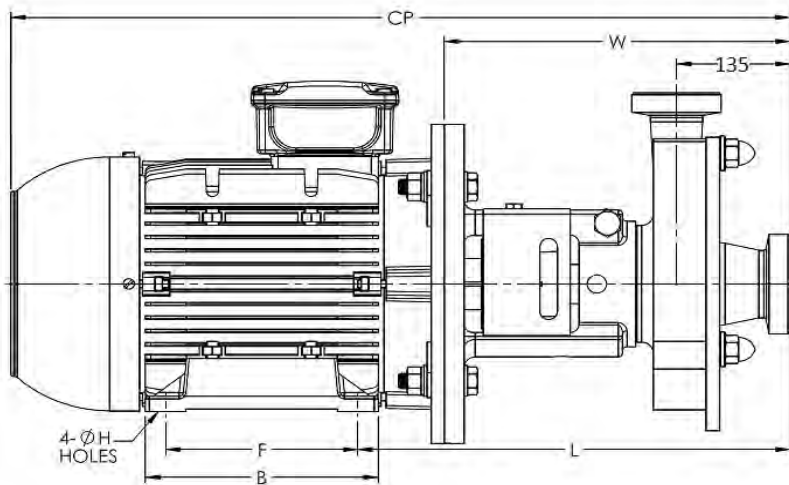

TEFC MOTOR			DIMENSIONS IN MILLIMETERS							(All Values For Reference Only) <small>Data subject to change without notice.</small>			MASS
kW	RPM	FRAME	A (typ)	B (typ)	D	E	F	ØH	L	W	CP	OP	Kg
0.75kW	1450	80	149	125.5	80	62.5	100	10	279	229	465	230	29
1.1kW	2900	80	149	125.5	80	62.5	100	10	279	229	465	230	28
1.5kW	2900	90S	164	156	90	70	100	10	285	229	507	240	33
2.2kW	2900	90L	164	156	90	70	125	10	285	229	507	240	33
3kW	2900	100L	188	173	100	80	140	12	315	252	568	250	46
4kW	2900	112M	220	177	112	95	140	12	322	252	586	262	56

MATERIAL SPECIFICATIONS

PART NAME	STAINLESS STEEL
Casing, Cover & Impeller	316L Stainless
Stub Shaft	316L Stainless
Adapter	304 Stainless

PUMP CURVES

MODEL LM-R21 50 x 40
MODEL LM-R22 50 x 40

Ampco Centrifugal Pumps

Curves show approximate characteristics based on clear 20°C water.
Rated point is guaranteed

LM-Series pumps have standard stainless steel adapters and silicon carbide vs. carbon seals.

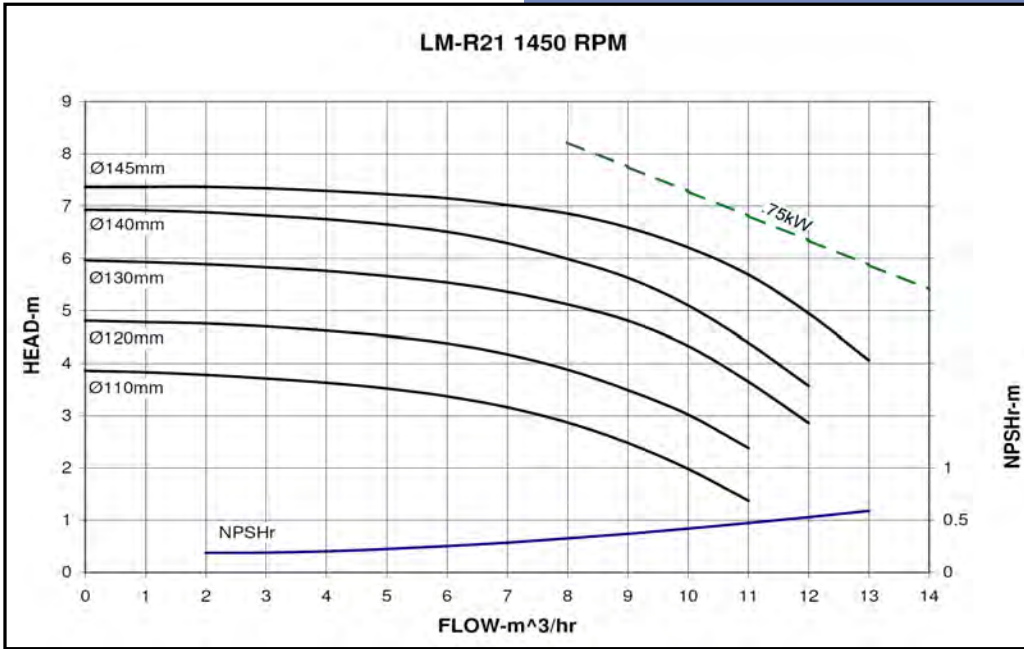
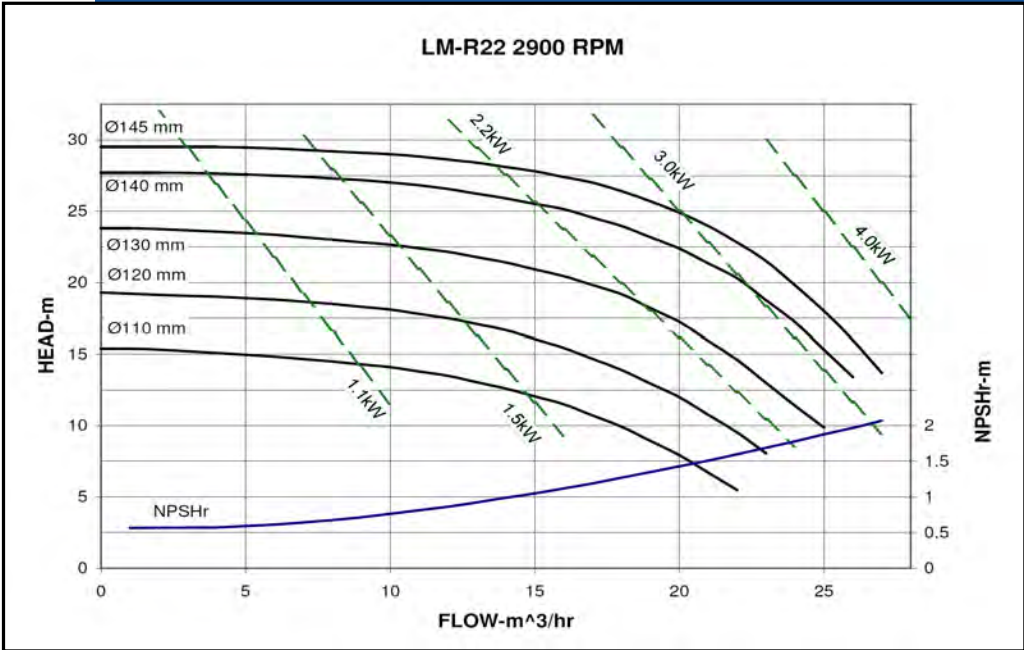

LM pumps are in conformance with 3A sanitary standards for centrifugal and positive rotary pumps for milk and milk products, Number 02-10.

LM-Series pumps have a standard 0.8µm (micrometers) finish, on all product contact surfaces.

Ampco Pumps Company

2045 West Mill Road
Glendale, Wisconsin 53209
PHONE (414) 643-1852
FAX (414) 643-4452

LM-R21/R22 50X40 01/11



Ampco Centrifugal Pumps

DATA SHEET

MODEL LM-R31 50 x 40

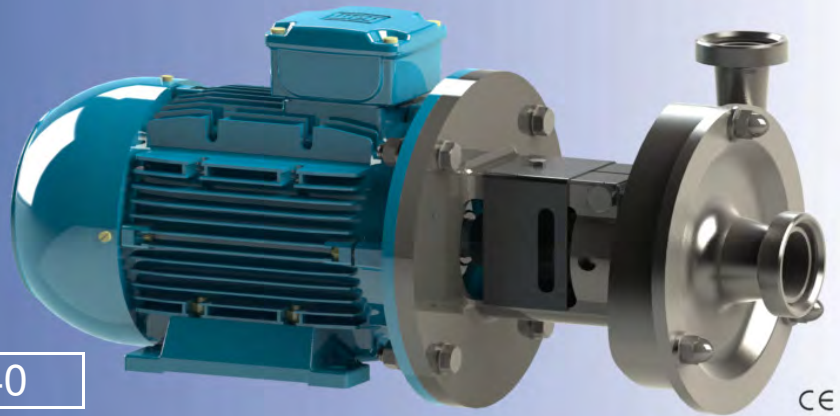

CE

Connections DIN 11851 thread

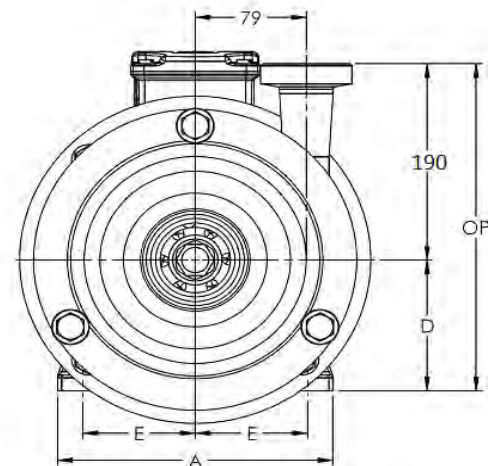
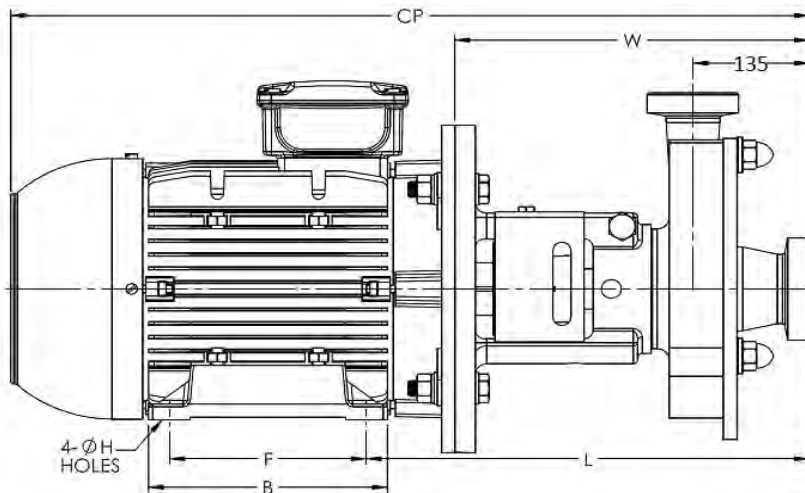

TEFC MOTOR			DIMENSIONS IN MILLIMETERS							(All Values For Reference Only) <small>Data subject to change without notice.</small>			MASS
kW	RPM	FRAME	A (typ)	B (typ)	D	E	F	ØH	L	W	CP	OP	Kg
0.75kW	1450	80	149	125.5	80	62.5	100	10	279	229	470	230	23
1.1kW	1450	90S	164	156	90	70	100	10	285	229	507	240	32
1.5kW	1450	90L	164	156	90	70	125	10	285	229	507	240	36
2.2kW	1450	100L	188	173	100	80	140	12	315	252	470	250	53

MATERIAL SPECIFICATIONS

PART NAME	STAINLESS STEEL
Casing, Cover & Impeller	316L Stainless
Stub Shaft	316L Stainless
Adapter	304 Stainless

Ampco Centrifugal Pumps

PUMP CURVE

MODEL LM-R31 50 x 40

Curves show approximate characteristics based on clear 20°C water.
Rated point is guaranteed

LM-Series pumps have standard stainless steel adapters and silicon carbide vs. carbon seals.

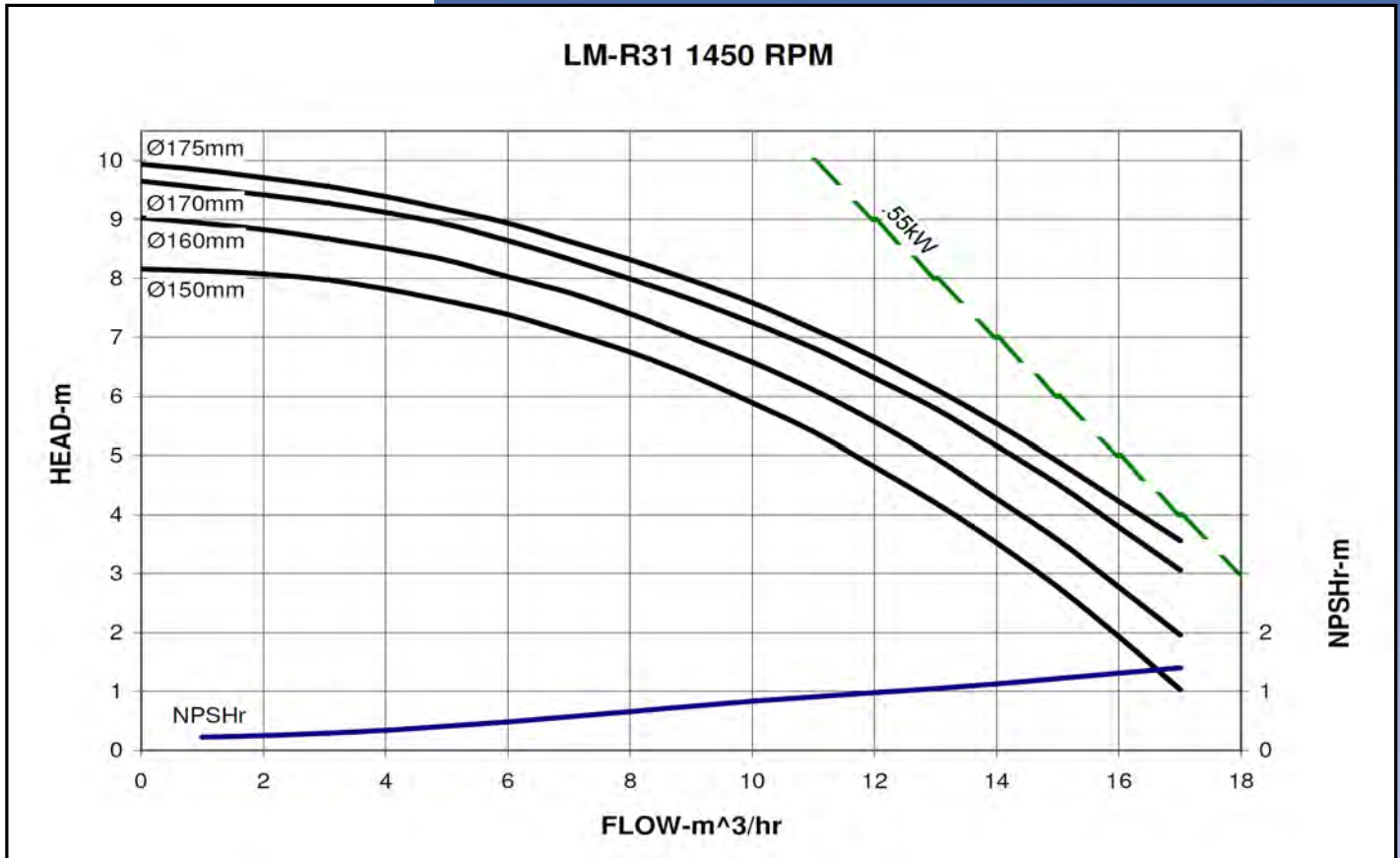

LM pumps are in conformance with 3A sanitary standards for centrifugal and positive rotary pumps for milk and milk products, Number 02-10.

LM-Series pumps have a standard 0.8µm (micrometers) finish, on all product contact surfaces.

AmpcoPumps Company

2045 West Mill Road-Glendale, Wisconsin 53209-PHONE (414) 643-1852-FAX (414) 643-4452

LM-R31 50X40 01/11

Ampco Centrifugal Pumps

DATA SHEET

MODEL LM-R41 65 x 50

MODEL LM-R42 65 x 50

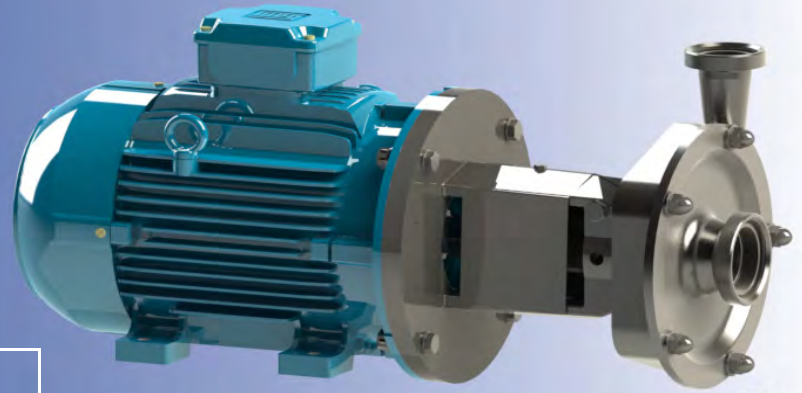

CE

Connections DIN 11851 thread

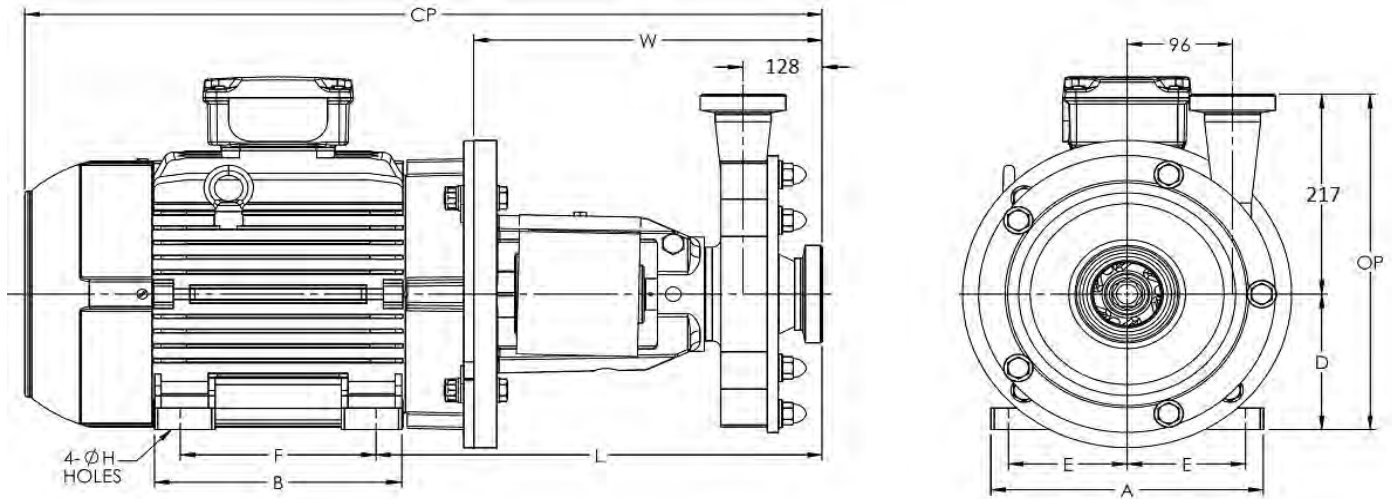

TEFC MOTOR			DIMENSIONS IN MILLIMETERS							(All Values For Reference Only) <small>Data subject to change without notice.</small>			MASS
kW	RPM	FRAME	A (typ)	B (typ)	D	E	F	ØH	L	W	CP	OP	Kg
.75kW	1450	80	149	125.5	80	62.5	100	10	273	223	470	275	34
1.1kW	1450	90S	164	131	90	70	100	10	279	223	470	285	37
1.5kW	1450	90L	164	156	90	70	125	10	279	223	470	285	41
2.2kW	1450	100L	188	173	100	80	140	12	310	247	507	295	58
5.5kW	2900	132S	248	187	132	108	140	12	406	317	726	327	89
7.5kW	2900	132S	248	187	132	108	140	12	406	317	726	327	89
11kW	2900	160M	308	254	160	127	210	14.5	425	317	805	355	159
15kW	2900	160M	308	254	160	127	210	14.5	425	317	805	355	160
18.5kW	2900	160L	308	298	160	127	254	14.5	425	317	805	355	179

MATERIAL SPECIFICATIONS

PART NAME	STAINLESS STEEL
Casing, Cover & Impeller	316L Stainless
Stub Shaft	316L Stainless
Adapter	304 Stainless

PUMP CURVES

MODEL LM-R41 65 x 50
MODEL LM-R42 65 x 50

Ampco Centrifugal Pumps

Curves show approximate characteristics based on clear 20°C water. Rated point is guaranteed

LM-Series pumps have standard stainless steel adapters and silicon carbide vs. carbon seals.

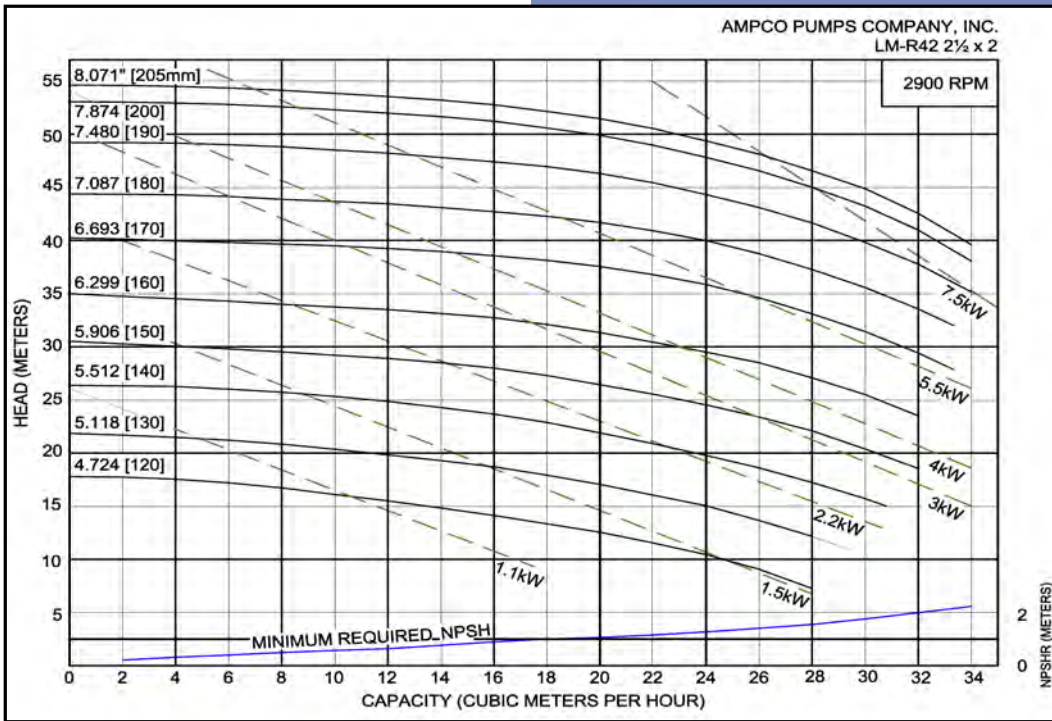
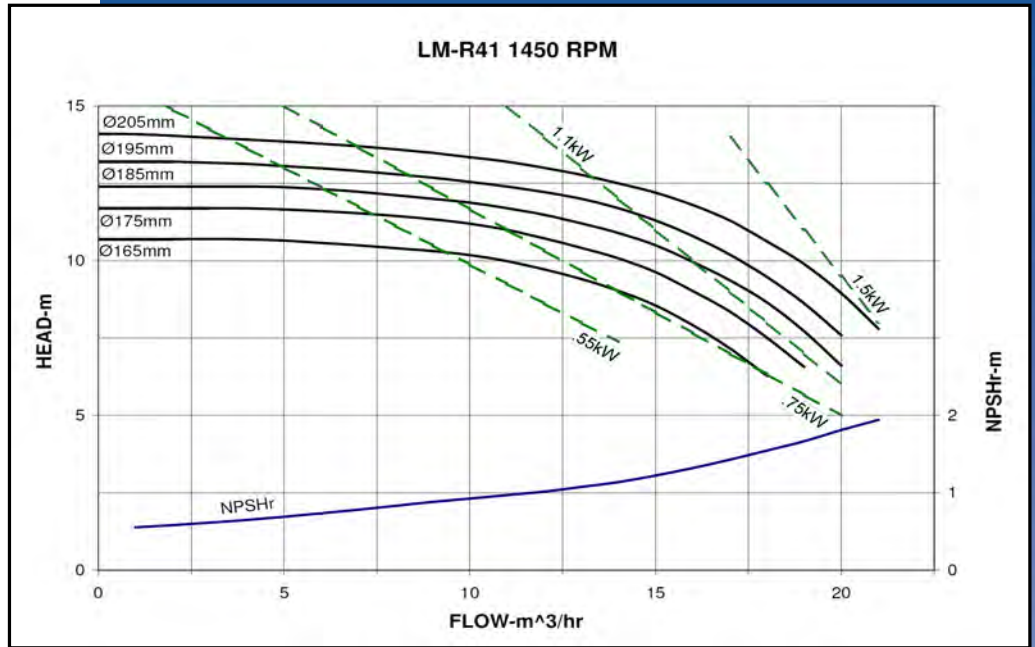

LM pumps are in conformance with 3A sanitary standards for centrifugal and positive rotary pumps for milk and milk products, Number 02-10.

LM-Series pumps have a standard 0.8µm (micrometers) finish, on all product contact surfaces.

Ampco Pumps Company

2045 West Mill Road
 Glendale, Wisconsin 53209
 PHONE (414) 643-1852
 FAX (414) 643-4452

LM-R41/R42 65X50 01/11



Ampco Centrifugal Pumps

DATA SHEET

MODEL LM-R141 65 x 50

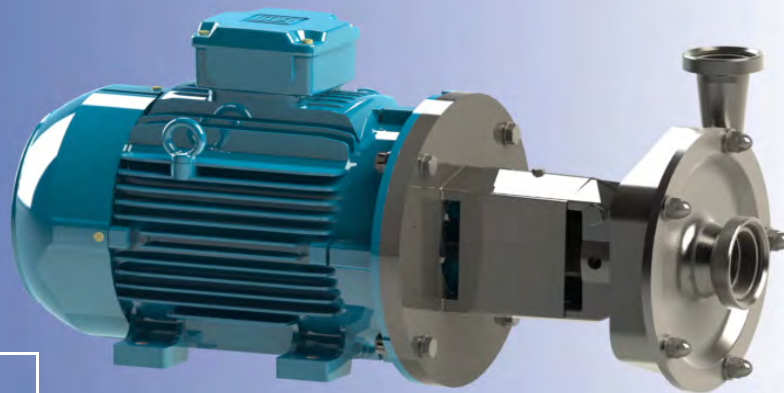

CE

Connections DIN 11851 thread

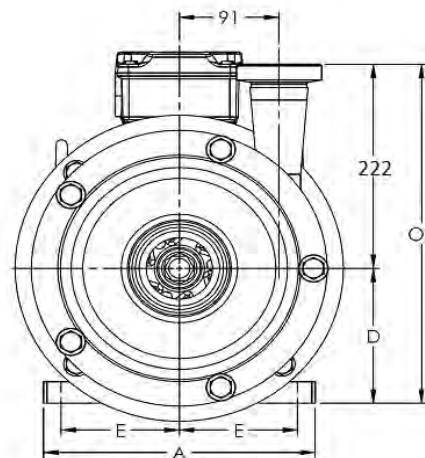
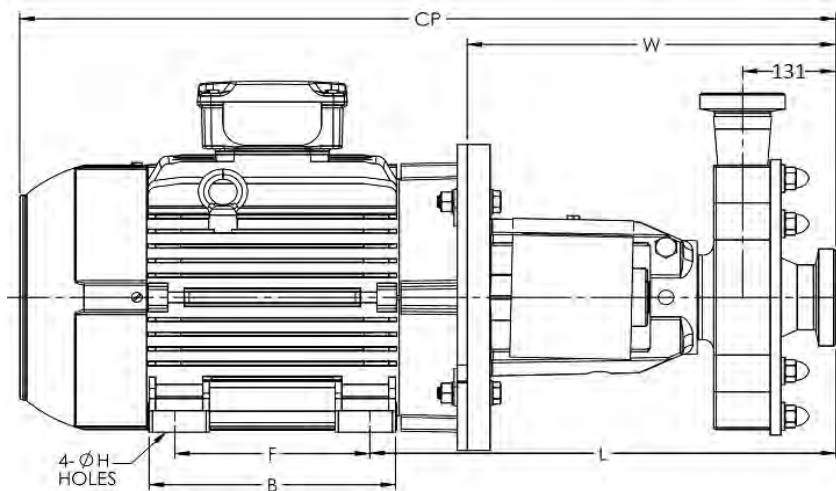

TEFC MOTOR			DIMENSIONS IN MILLIMETERS							(All Values For Reference Only) <small>Data subject to change without notice.</small>			MASS
kW	RPM	FRAME	A (typ)	B (typ)	D	E	F	ØH	L	W	CP	OP	Kg
.75kW	1450	80	149	125.5	80	62.5	100	10	273	223	470	275	34
1.1kW	1450	90S	164	131	90	70	100	10	279	223	470	285	37
1.5kW	1450	90L	164	156	90	70	125	10	279	223	470	285	41
2.2kW	1450	100L	188	173	100	80	140	12	310	247	507	295	58
4kW	1450	112M	220	177	112	95	140	12	317	247	470	307	70
5.5kW	1450	132S	248	187	132	108	140	12	406	317	507	327	104

MATERIAL SPECIFICATIONS

PART NAME	STAINLESS STEEL
Casing, Cover & Impeller	316L Stainless
Stub Shaft	316L Stainless
Adapter	304 Stainless

Ampco Centrifugal Pumps

PUMP CURVE

MODEL LM-R141 65 x 50

Curves show approximate characteristics based on clear 20°C water.
Rated point is guaranteed

LM-Series pumps have standard stainless steel adapters and silicon carbide vs. carbon seals.

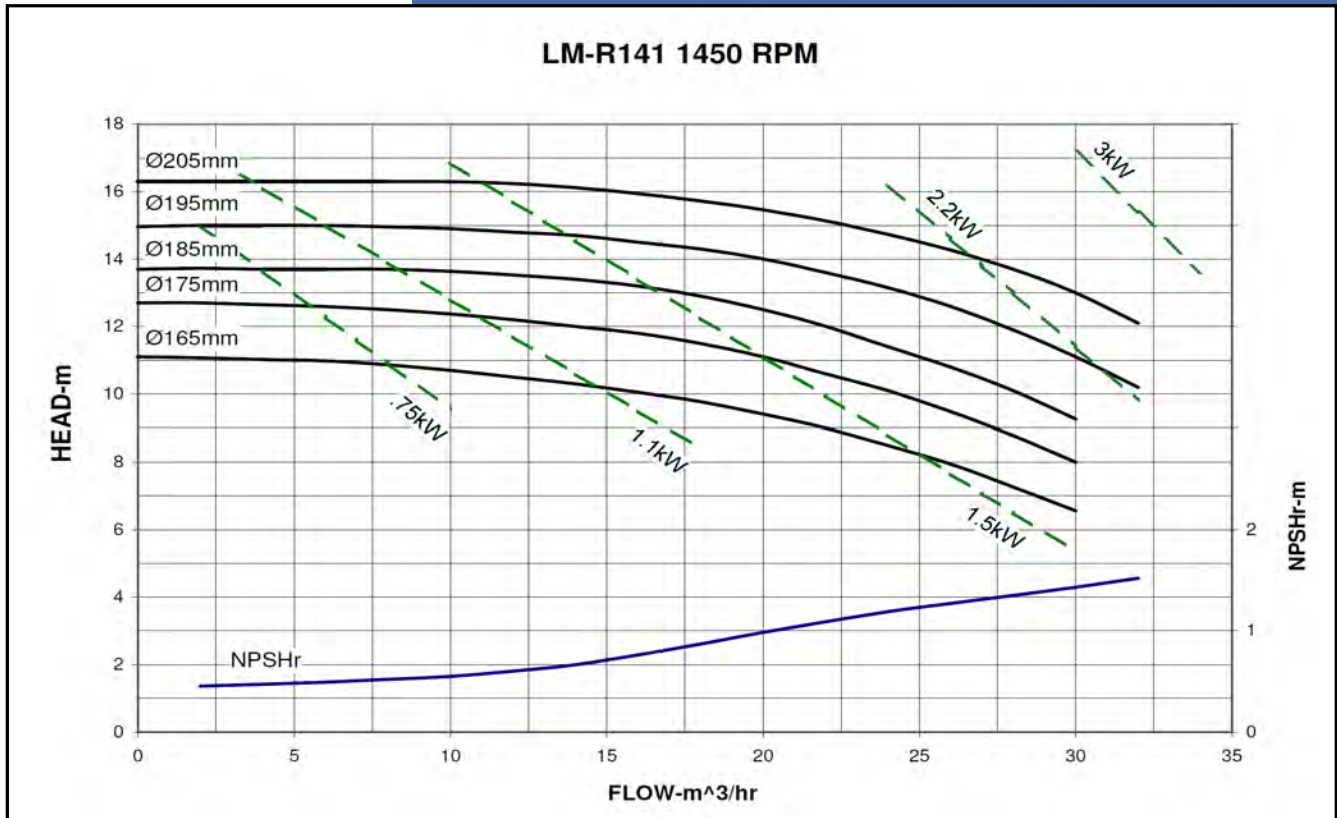

LM pumps are in conformance with 3A sanitary standards for centrifugal and positive rotary pumps for milk and milk products, Number 02-10.

LM-Series pumps have a standard 0.8µm (micrometers) finish, on all product contact surfaces.

AmpcoPumps Company

2045 West Mill Road-Glendale, Wisconsin 53209-PHONE (414) 643-1852-FAX (414) 643-4452

LM-R141 65X50 01/11

Ampco Centrifugal Pumps

DATA SHEET

MODEL LM-R142 65 x 50

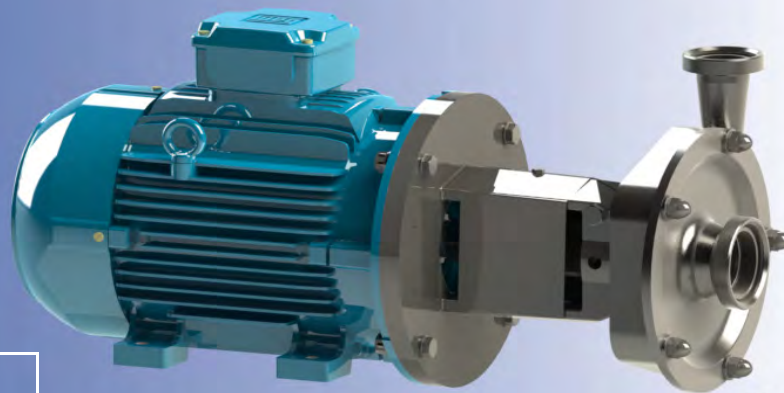

CE

Connections DIN 11851 thread

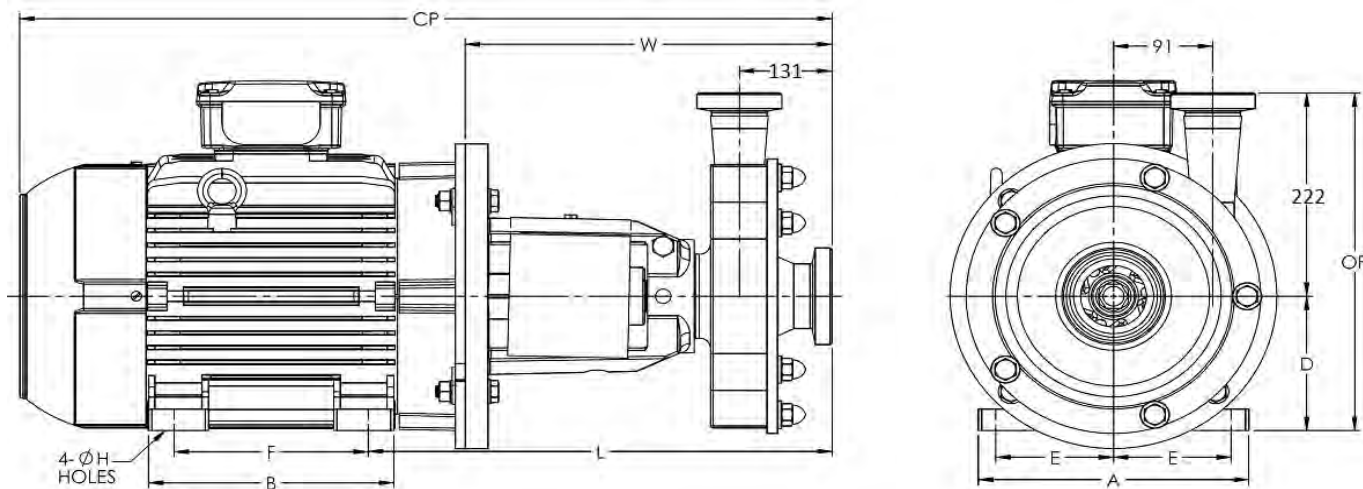

TEFC MOTOR			DIMENSIONS IN MILLIMETERS							(All Values For Reference Only) <small>Data subject to change without notice.</small>			MASS
kW	RPM	FRAME	A (typ)	B (typ)	D	E	F	ØH	L	W	CP	OP	Kg
7.5kW	2900	132S	248	187	132	108	140	12	406	317	726	327	89
11kW	2900	160M	308	254	160	127	210	12	425	317	726	355	155
15kW	2900	160M	308	254	160	127	210	14.5	425	317	805	355	160
18.5kW	2900	160L	308	298	160	127	254	14.5	425	317	805	355	179
22kW	2900	180M	350	294	180	139.5	241	14.5	438	317	870	375	236
30kW	2900	200L	385	370	200	159	305	18.5	450	317	935	395	307
37kW	2900	200L	385	370	200	159	305	18.5	450	317	935	395	322

MATERIAL SPECIFICATIONS

PART NAME	STAINLESS STEEL
Casing, Cover & Impeller	316L Stainless
Stub Shaft	316L Stainless
Adapter	304 Stainless

Ampco Centrifugal Pumps

PUMP CURVE

MODEL LM-R142 65 x 50

Curves show approximate characteristics based on clear 20°C water.
Rated point is guaranteed

LM-Series pumps have standard stainless steel adapters and silicon carbide vs. carbon seals.

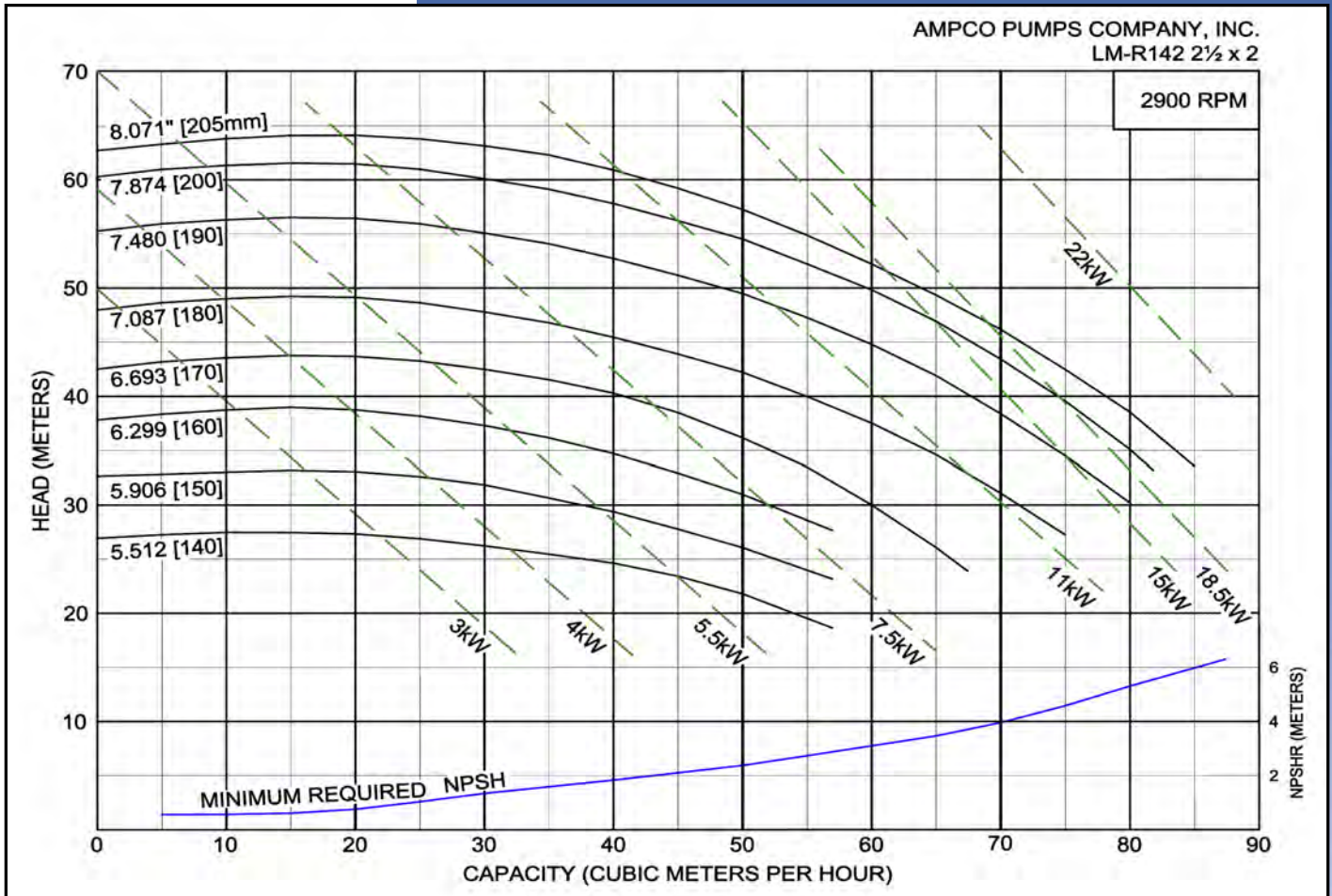

LM pumps are in conformance with 3A sanitary standards for centrifugal and positive rotary pumps for milk and milk products, Number 02-10.

LM-Series pumps have a standard 0.8µm (micrometers) finish, on all product contact surfaces.

AmpcoPumps Company

2045 West Mill Road-Glendale, Wisconsin 53209-PHONE (414) 643-1852-FAX (414) 643-4452

LM-R142 65X50 01/11



Ampco Centrifugal Pumps

DATA SHEET

MODEL LM-V521 65 x 50

MODEL LM-V522 65 x 50

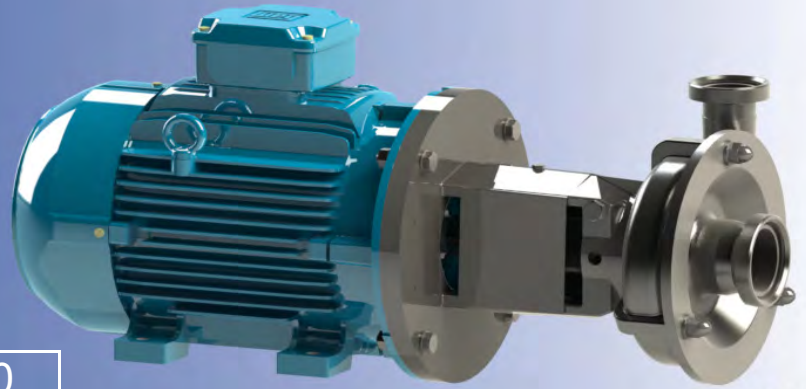

CE

Connections DIN 11851 thread

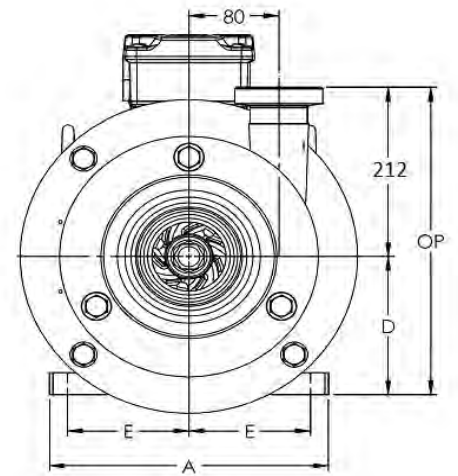
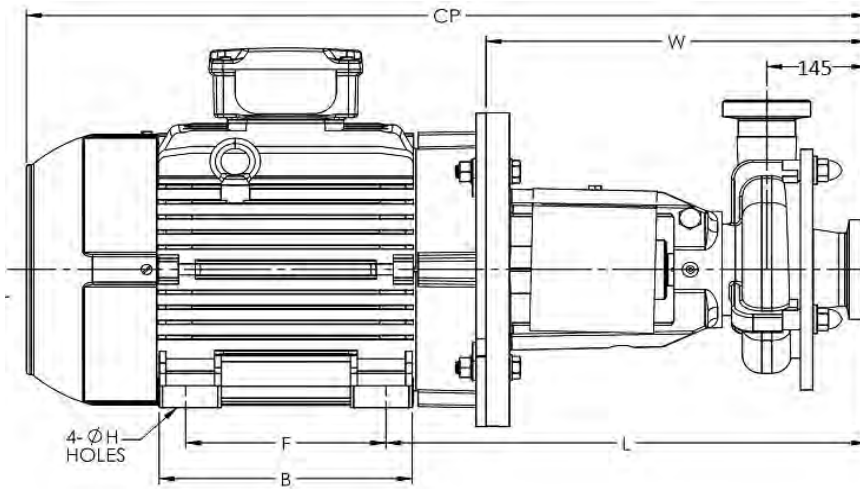

TEFC MOTOR			DIMENSIONS IN MILLIMETERS							(All Values For Reference Only) <small>Data subject to change without notice.</small>			MASS
kW	RPM	FRAME	A (typ)	B (typ)	D	E	F	ØH	L	W	CP	OP	Kg
0.75kW	1450	80	149	125.5	80	62.5	100	10	295	245	523	270	30
1.1kW	1450	90S	164	131	90	70	100	10	301	245	523	280	34
1.5kW	1450	90L	164	156	90	70	125	10	301	245	523	280	37
4kW	2900	112M	220	177	112	95	140	12	338	268	602	302	57
5.5kW	2900	132S	248	187	132	108	140	12	428	339	747	322	85
7.5kW	2900	132S	248	187	132	108	140	12	428	339	747	322	85
11kW	2900	160M	308	254	160	127	210	14.5	447	339	834	350	154

MATERIAL SPECIFICATIONS

PART NAME	STAINLESS STEEL
Casing, Cover & Impeller	316L Stainless
Stub Shaft	316L Stainless
Adapter	304 Stainless

PUMP CURVES

MODEL LM-V521 65 x 50
MODEL LM-V522 65 x 50

Ampco Centrifugal Pumps

Curves show approximate characteristics based on clear 20°C water. Rated point is guaranteed

LM-Series pumps have standard stainless steel adapters and silicon carbide vs. carbon seals.

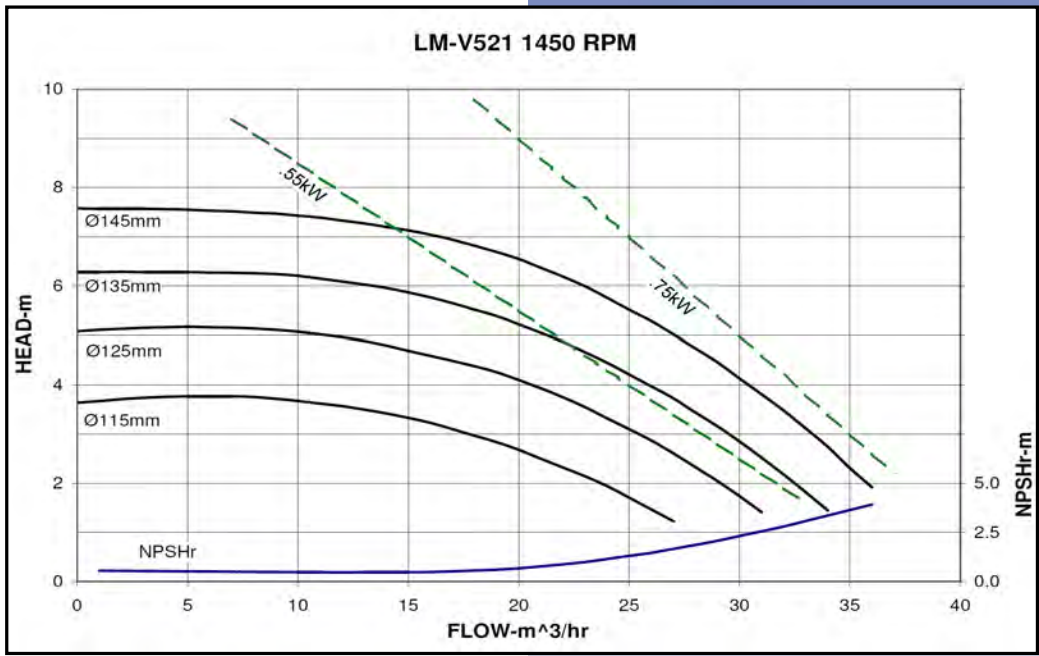
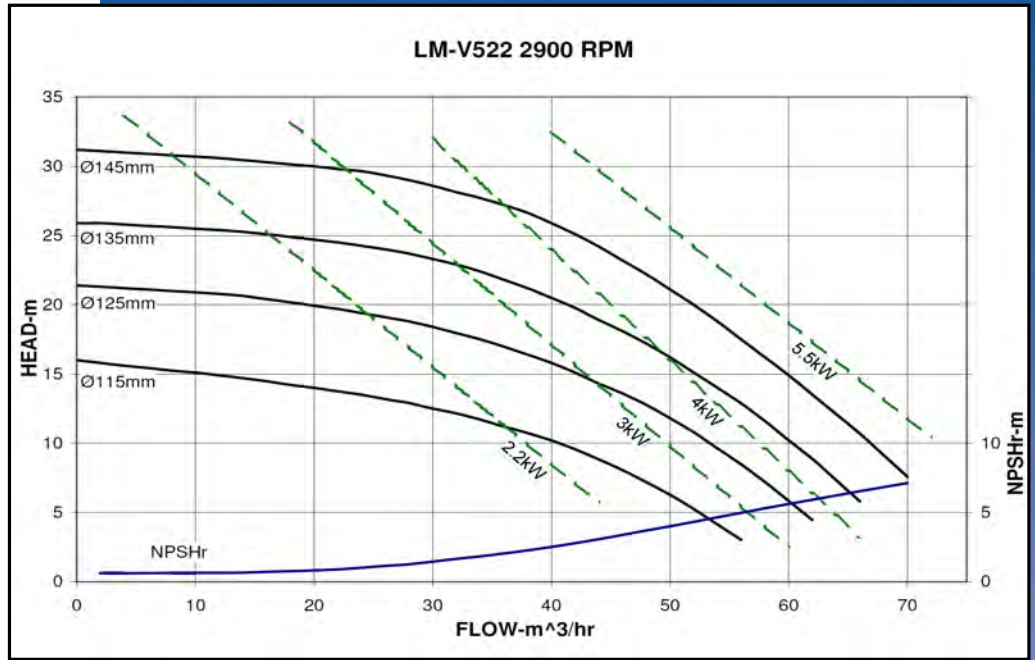

LM pumps are in conformance with 3A sanitary standards for centrifugal and positive rotary pumps for milk and milk products, Number 02-10.

LM-Series pumps have a standard 0.8µm (micrometers) finish, on all product contact surfaces.

Ampco Pumps Company

2045 West Mill Road
 Glendale, Wisconsin 53209
 PHONE (414) 643-1852
 FAX (414) 643-4452

LM-V521/V522 65X50 01/11



Ampco Centrifugal Pumps

DATA SHEET

MODEL LM-V531 65 x 50

MODEL LM-V532 65 x 50

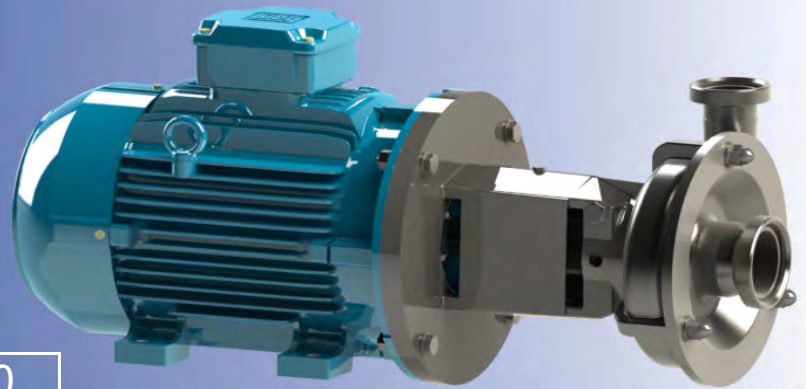

CE

Connections DIN 11851 thread

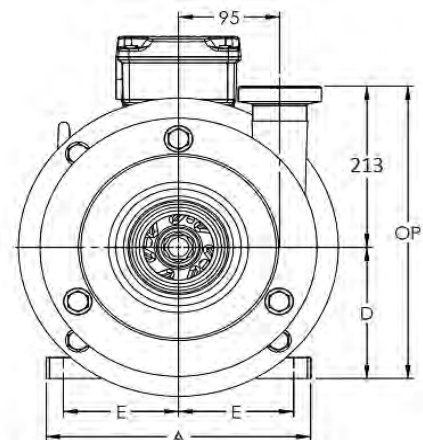
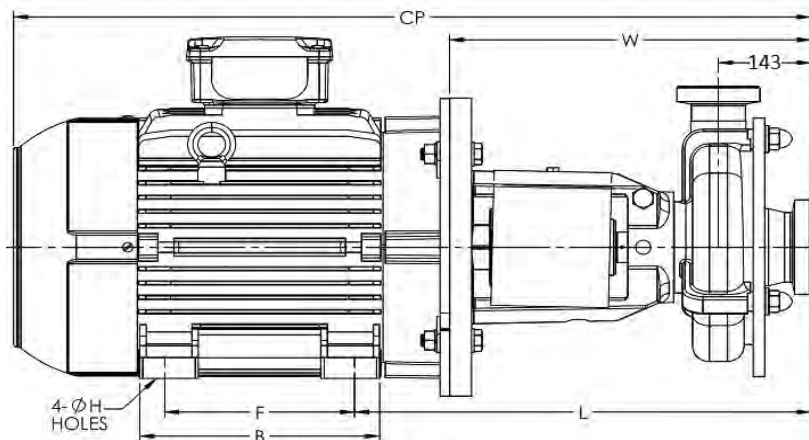

TEFC MOTOR			DIMENSIONS IN MILLIMETERS							(All Values For Reference Only) <small>Data subject to change without notice.</small>			MASS
kW	RPM	FRAME	A (typ)	B (typ)	D	E	F	ØH	L	W	CP	OP	Kg
0.75kW	1450	80	149	125.5	80	62.5	100	10	295	245	481	242	32
1.1kW	1450	90S	164	131	90	70	100	10	301	245	523	252	36
1.5kW	1450	90L	164	156	90	70	125	10	301	245	523	252	40
2.2kW	1450	100L	188	173	100	80	140	12	332	269	603	262	66
4kW	1450	112M	220	177	112	95	140	12	339	269	603	274	77
4kW	2900	112M	220	177	112	95	140	12	339	269	603	274	68
5.5kW	2900	132S	248	187	132	108	140	12	428	339	748	294	87
7.5kW	2900	132S	248	187	132	108	140	12	428	339	748	294	87
11kW	2900	160M	308	254	160	127	210	14.5	447	339	827	322	157
15kW	2900	160M	308	254	160	127	210	14.5	447	339	827	322	158
18.5kW	2900	160L	308	298	160	127	254	14.5	447	339	827	322	177

MATERIAL SPECIFICATIONS

PART NAME	STAINLESS STEEL
Casing, Cover & Impeller	316L Stainless
Stub Shaft	316L Stainless
Adapter	304 Stainless

PUMP CURVES

MODEL LM-V531 65 x 50
MODEL LM-V532 65 x 50

Ampco Centrifugal Pumps

Curves show approximate characteristics based on clear 20°C water. Rated point is guaranteed

LM-Series pumps have standard stainless steel adapters and silicon carbide vs. carbon seals.

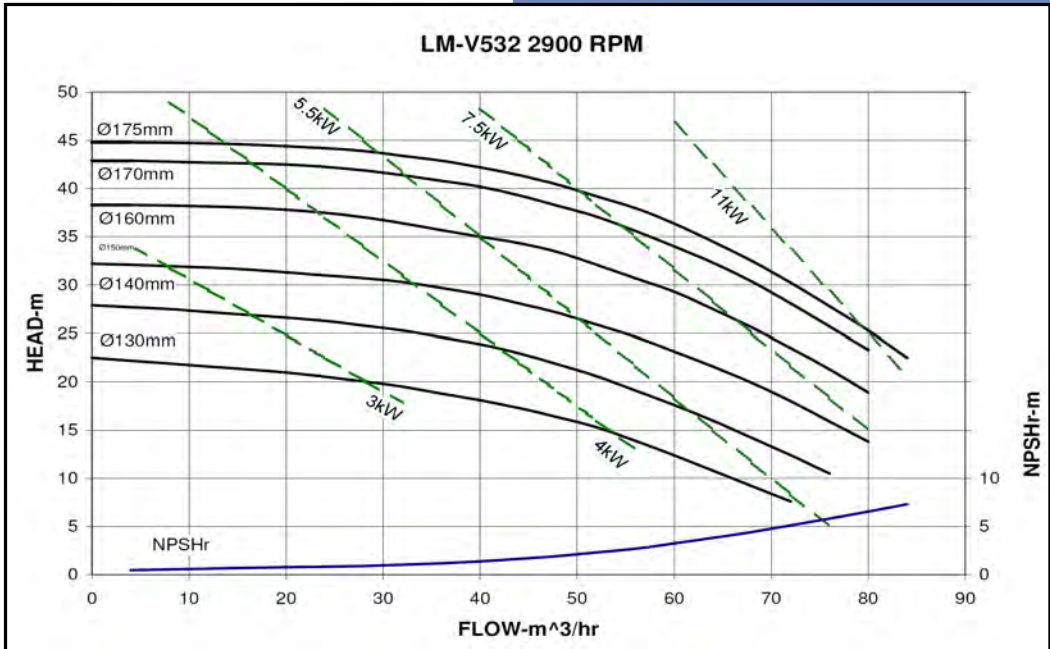

LM pumps are in conformance with 3A sanitary standards for centrifugal and positive rotary pumps for milk and milk products, Number 02-10.

LM-Series pumps have a standard 0.8µm (micrometers) finish, on all product contact surfaces.

Ampco Pumps Company

2045 West Mill Road
 Glendale, Wisconsin 53209
 PHONE (414) 643-1852
 FAX (414) 643-4452

LM-V531/V532 65X50 01/11



Ampco Centrifugal Pumps

DATA SHEET

MODEL LM-V541 80 x 65

MODEL LM-V542 80 x 65

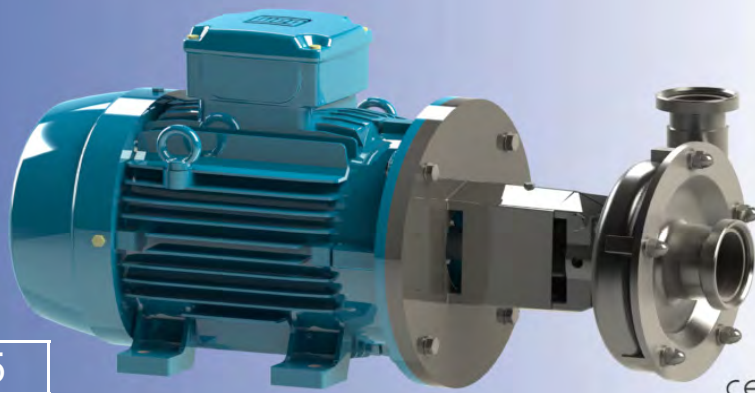

Connections DIN 11851 thread

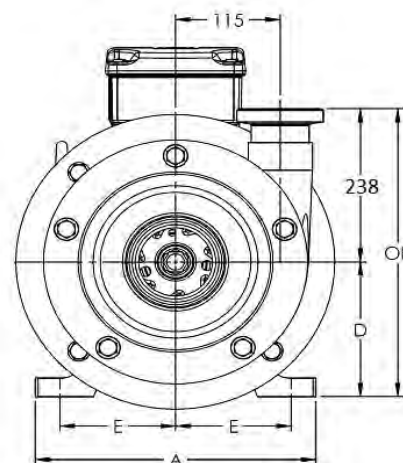
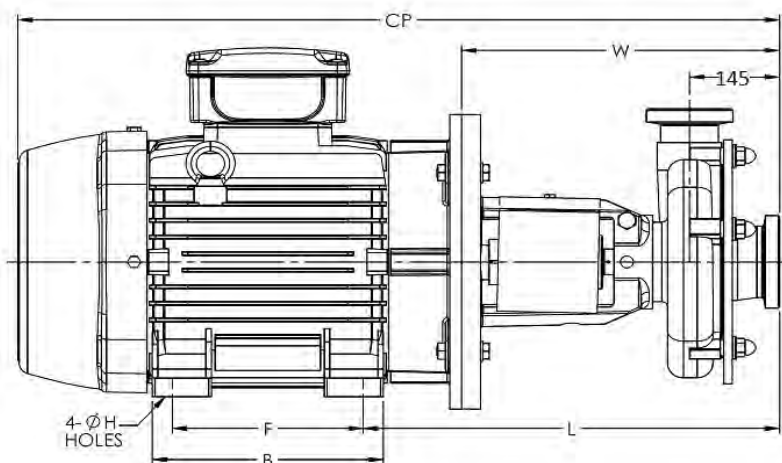

TEFC MOTOR			DIMENSIONS IN MILLIMETERS									(All Values For Reference Only)	MASS
			<small>Data subject to change without notice.</small>										
kW	RPM	FRAME	A (typ)	B (typ)	D	E	F	ØH	L	W	CP	OP	Kg
1.1kW	1450	90S	164	131	90	70	100	10	335	279	534	272	43
1.5kW	1450	90L	164	156	90	70	125	10	335	279	534	272	47
2.2kW	1450	100L	188	173	100	80	140	12	342	279	613	282	61
4kW	1450	112M	220	177	112	95	140	12	349	279	613	294	81
7.5kW	2900	132S	248	187	132	108	140	12	438	349	758	314	92
11kW	2900	160M	308	254	160	254	210	14.5	457	349	758	342	162
15kW	2900	160M	308	254	160	254	210	14.5	457	349	837	342	162
18.5kW	2900	160L	308	298	160	254	254	14.5	457	349	837	342	182
22kW	2900	180M	350	294	180	139.5	241	14.5	470	349	903	362	238
30kW	2900	200L	385	370	200	159	305	18.5	482	349	967	382	309
37kW	2900	200L	385	370	200	159	305	18.5	482	349	967	382	324

MATERIAL SPECIFICATIONS

PART NAME	STAINLESS STEEL
Casing, Cover & Impeller	316L Stainless
Stub Shaft	316L Stainless
Adapter	304 Stainless



PUMP CURVES

MODEL LM-V541 80 x 65
MODEL LM-V542 80 x 65

Ampco Centrifugal Pumps

Curves show approximate characteristics based on clear 20°C water. Rated point is guaranteed

LM-Series pumps have standard stainless steel adapters and silicon carbide vs. carbon seals.

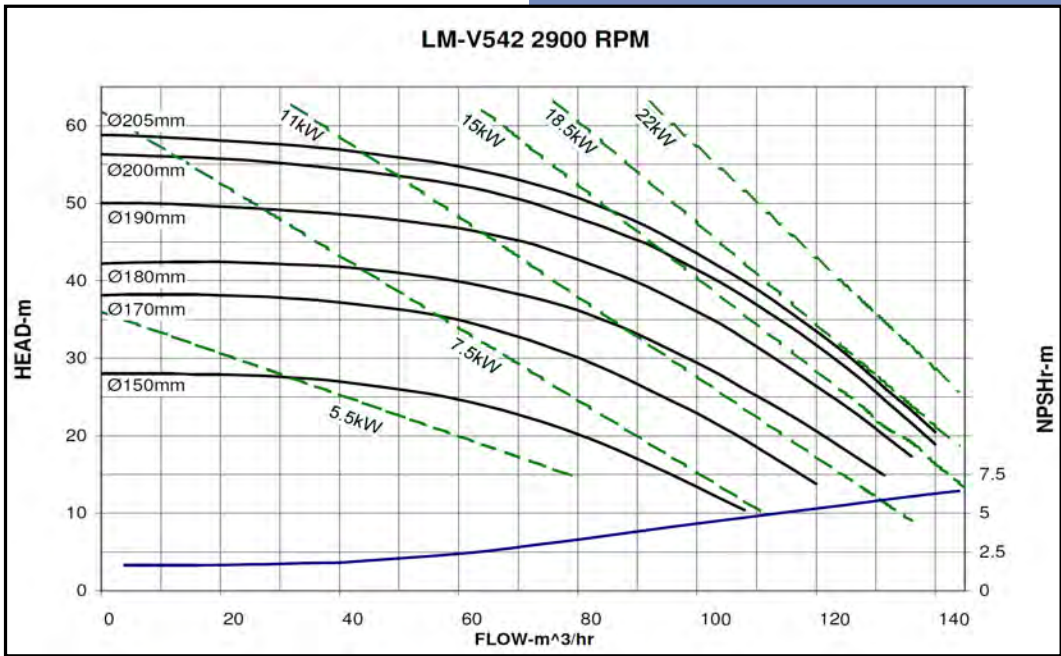
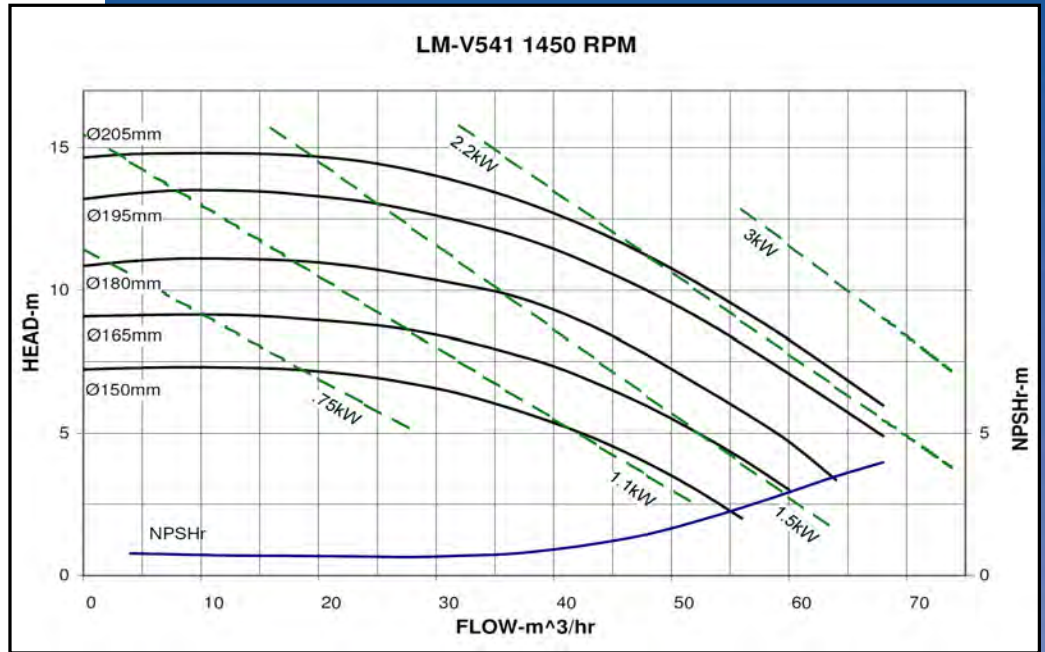

LM pumps are in conformance with 3A sanitary standards for centrifugal and positive rotary pumps for milk and milk products, Number 02-10.

LM-Series pumps have a standard 0.8µm (micrometers) finish, on all product contact surfaces.

Ampco Pumps Company

2045 West Mill Road
 Glendale, Wisconsin 53209
 PHONE (414) 643-1852
 FAX (414) 643-4452

LM-V541/V542 80X65 01/11



Ampco Centrifugal Pumps

DATA SHEET

MODEL LM-V551 80 x 65

MODEL LM-V552 80 x 65

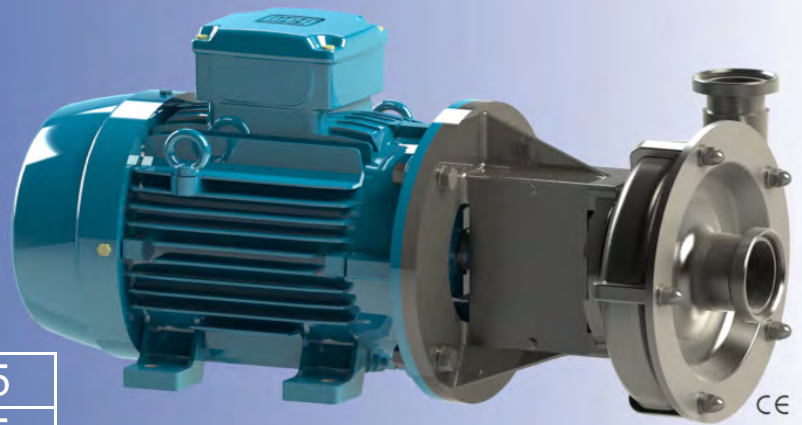

Connections DIN 11851 thread

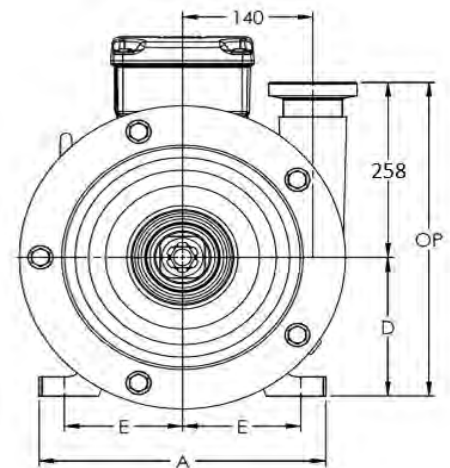
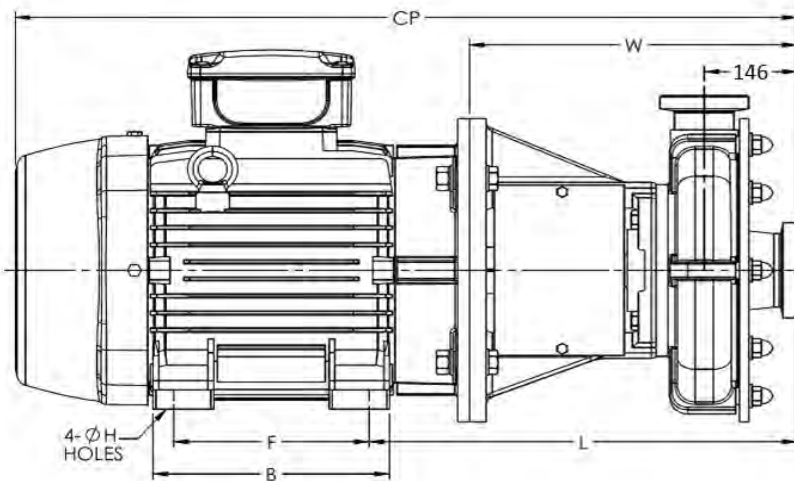

TEFC MOTOR			DIMENSIONS IN MILLIMETERS							(All Values For Reference Only) <small>Data subject to change without notice.</small>			MASS
kW	RPM	FRAME	A (typ)	B (typ)	D	E	F	ØH	L	W	CP	OP	Kg
2.2kW	1450	100L	188	173	100	80	140	12	328	265	659	302	76
3kW	1450	100L	188	173	100	80	140	12	328	265	659	302	76
4kW	1450	112M	220	177	112	95	140	12	335	265	659	314	100
5.5kW	1450	132S	248	187	132	108	140	12	441	352	761	334	122
7.5kW	1450	132M	248	225	132	108	178	12	441	352	761	334	124
18.5kW	2900	160L	308	298	160	127	254	14.5	460	352	840	362	197
22kW	2900	180M	350	294	180	139.5	241	14.5	473	352	905	382	254
30kW	2900	200L	385	370	200	159	305	18.5	485	352	970	402	325
37kW	2900	200L	385	370	200	159	305	18.5	485	352	970	402	340
45kW	2900	225S/M	436	391	225	178	*	18.5	501	352	*	427	495

MATERIAL SPECIFICATIONS

* Contact Ampco Pumps Company

PART NAME	STAINLESS STEEL
Casing, Cover & Impeller	316L Stainless
Stub Shaft	316L Stainless
Adapter	304 Stainless



PUMP CURVES

MODEL LM-V551 80 x 65

MODEL LM-V552 80 x 65

Ampco Centrifugal Pumps

Curves show approximate characteristics based on clear 20°C water. Rated point is guaranteed

LM-Series pumps have standard stainless steel adapters and silicon carbide vs. carbon seals.

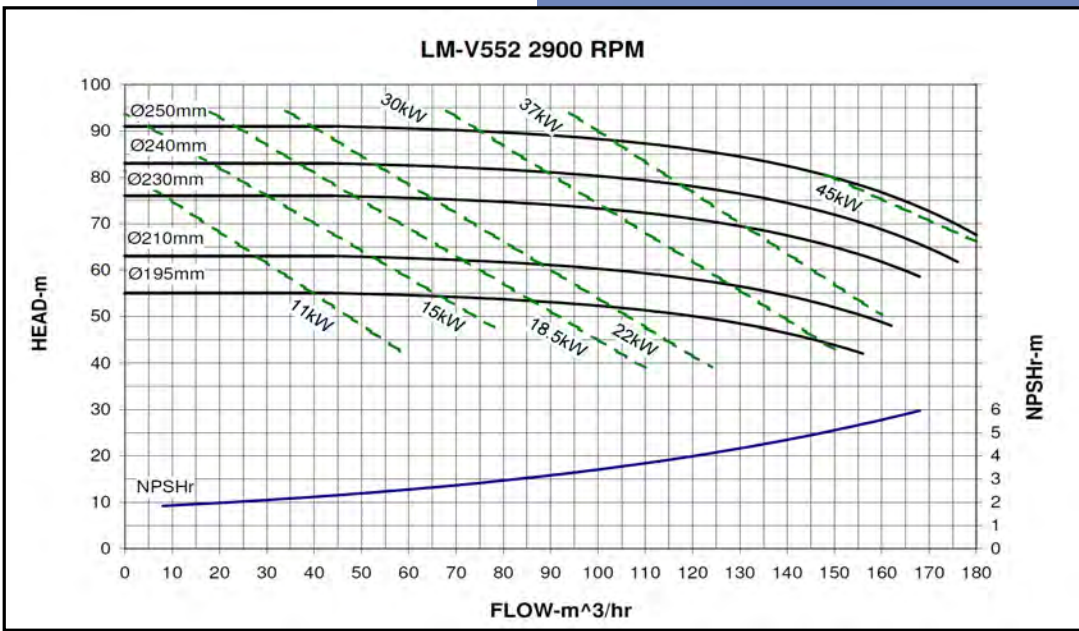
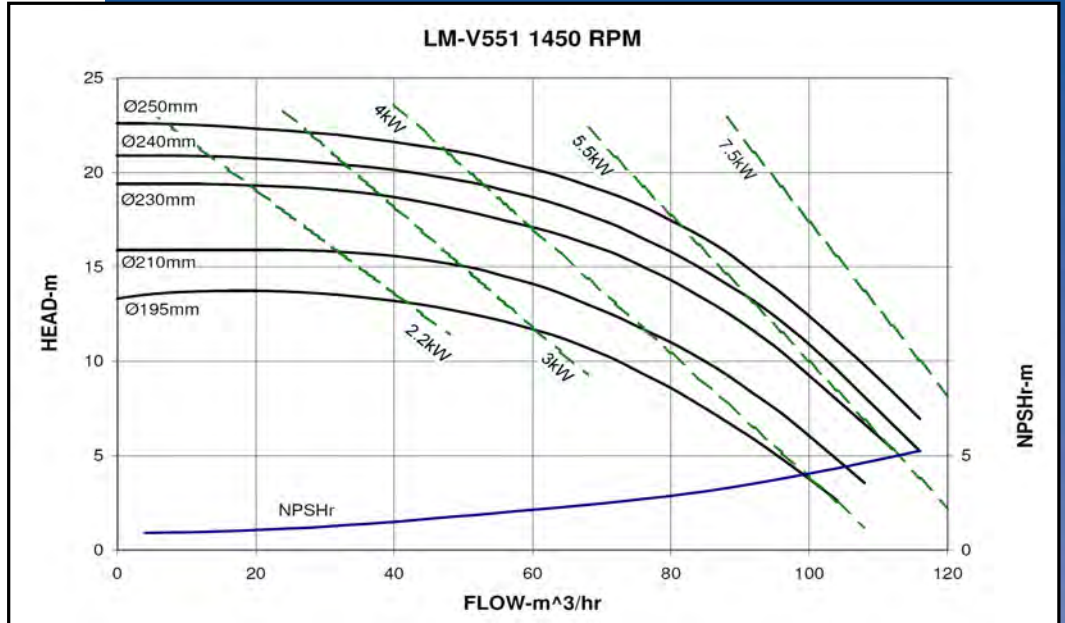

LM pumps are in conformance with 3A sanitary standards for centrifugal and positive rotary pumps for milk and milk products, Number 02-10.

LM-Series pumps have a standard 0.8µm (micrometers) finish, on all product contact surfaces.

Ampco Pumps Company

2045 West Mill Road
 Glendale, Wisconsin 53209
 PHONE (414) 643-1852
 FAX (414) 643-4452

LM-V551/552 80X65 01/11



Ampco Centrifugal Pumps

DATA SHEET

MODEL LM-X051 100 x 100

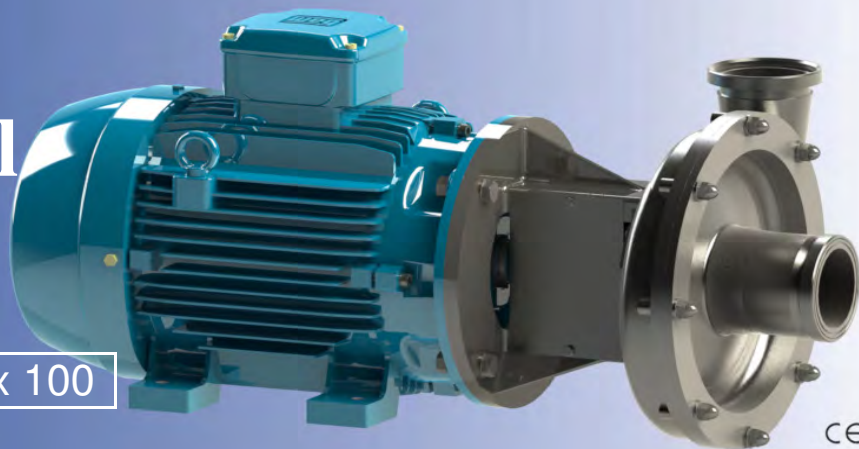

Connections DIN 11851 thread

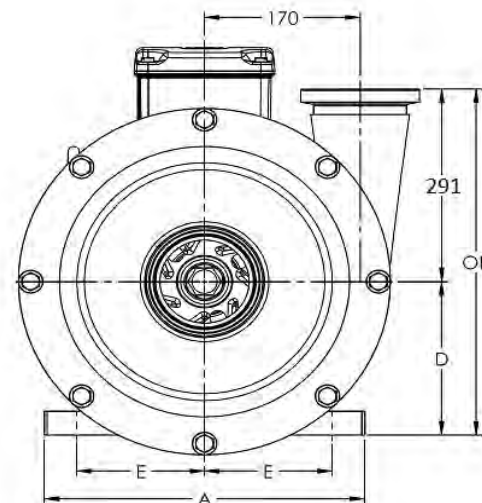
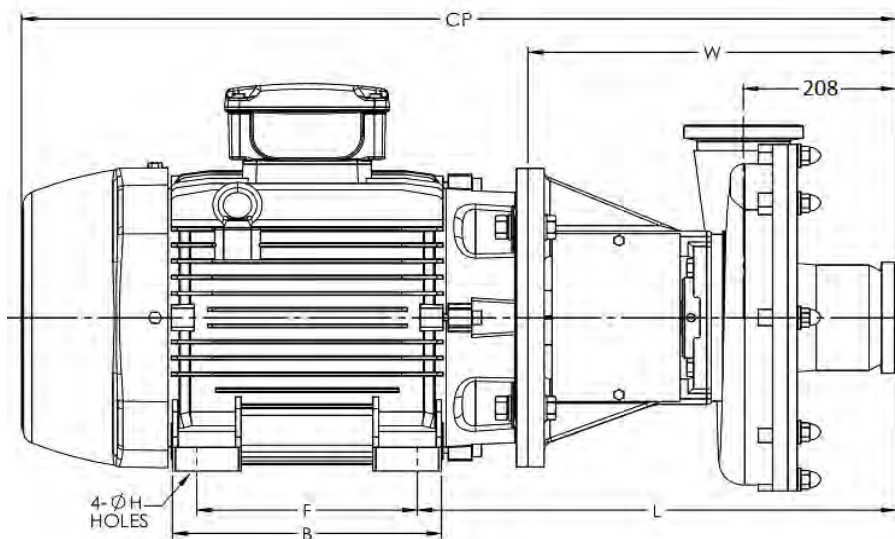

TEFC MOTOR			DIMENSIONS IN MILLIMETERS							(All Values For Reference Only) <small>Data subject to change without notice.</small>			MASS
kW	RPM	FRAME	A (typ)	B (typ)	D	E	F	ØH	L	W	CP	OP	Kg
5.5kW	1450	132S	248	187	132	108	140	12	491	402	811	358	135
7.5kW	1450	132M	248	225	132	108	178	12	491	402	811	358	138
11kW	1450	160M	308	254	160	127	210	14.5	510	402	897	386	206
15kW	1450	160L	308	298	160	127	254	14.5	510	402	897	386	211
18.5kW	1450	180M	350	294	180	139.5	241	14.5	523	402	957	406	263

MATERIAL SPECIFICATIONS

PART NAME	STAINLESS STEEL
Casing, Cover & Impeller	316L Stainless
Stub Shaft	316L Stainless
Adapter	304 Stainless

Ampco Centrifugal Pumps

PUMP CURVE

MODEL LM-X051 100 x 100

Curves show approximate characteristics based on clear 20°C water.
Rated point is guaranteed

LM-Series pumps have standard stainless steel adapters and silicon carbide vs. carbon seals.

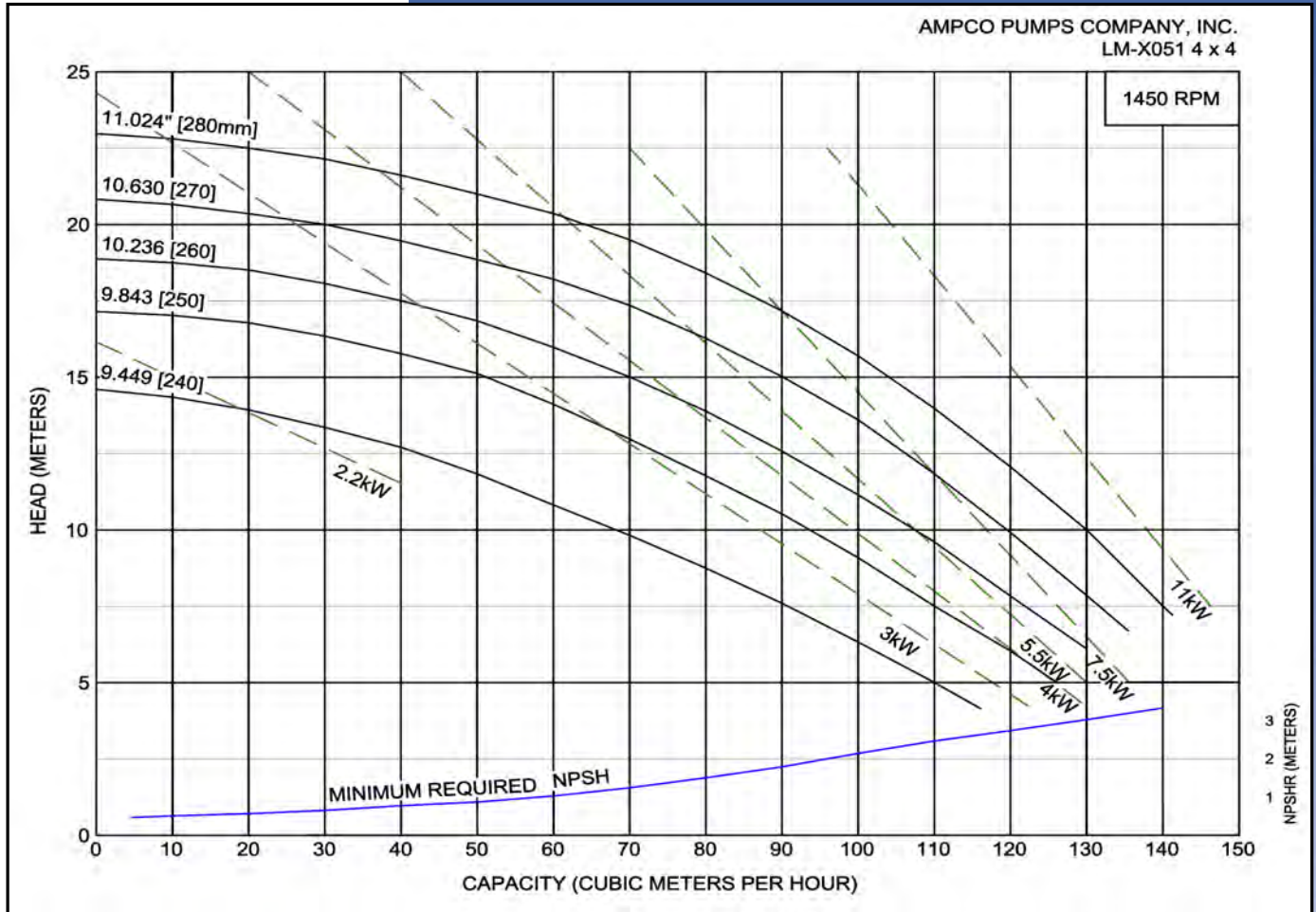

LM pumps are in conformance with 3A sanitary standards for centrifugal and positive rotary pumps for milk and milk products, Number 02-10.

LM-Series pumps have a standard 0.8µm (micrometers) finish, on all product contact surfaces.

AmpcoPumps Company

2045 West Mill Road-Glendale, Wisconsin 53209-PHONE (414) 643-1852-FAX (414) 643-4452

LM-X051 100X100 1/11

Ampco Centrifugal Pumps

DATA SHEET

MODEL LM-X161 100 x 100

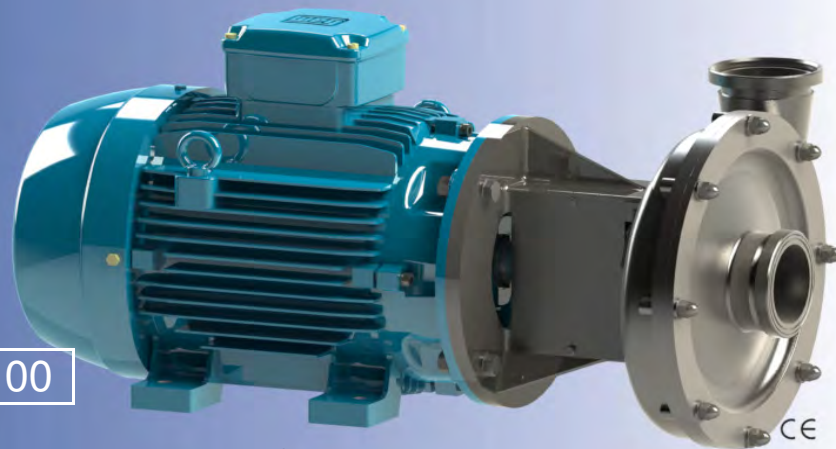

Connections DIN 11851 thread

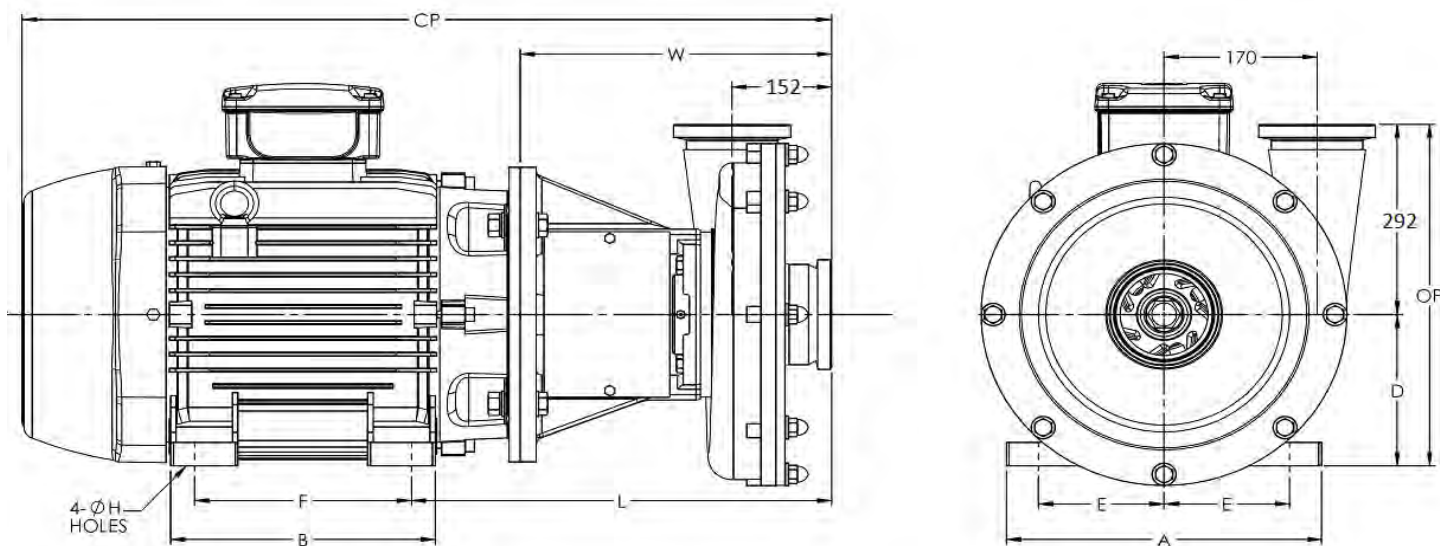

TEFC MOTOR			DIMENSIONS IN MILLIMETERS							(All Values For Reference Only) <small>Data subject to change without notice.</small>			MASS
kW	RPM	FRAME	A (typ)	B (typ)	D	E	F	ØH	L	W	CP	OP	Kg
7.5kW	1450	132M	248	225	132	108	178	12	435	346	755	358	135
11kW	1450	160M	308	254	160	127	210	14.5	454	346	841	386	203
15kW	1450	160L	308	298	160	127	254	14.5	454	346	841	386	208
18.5kW	1450	180M	350	294	180	139.5	241	14.5	467	346	899	406	260
22kW	1450	180L	350	332	180	139.5	279	14.5	467	346	899	406	280
30kW	1450	200L	385	370	200	159	305	18.5	479	346	964	426	331

MATERIAL SPECIFICATIONS

PART NAME	STAINLESS STEEL
Casing, Cover & Impeller	316L Stainless
Stub Shaft	316L Stainless
Adapter	304 Stainless

Ampco Centrifugal Pumps

PUMP CURVE

MODEL LM-X161 100 x 100

Curves show approximate characteristics based on clear 20°C water.
Rated point is guaranteed

LM-Series pumps have standard stainless steel adapters and silicon carbide vs. carbon seals.

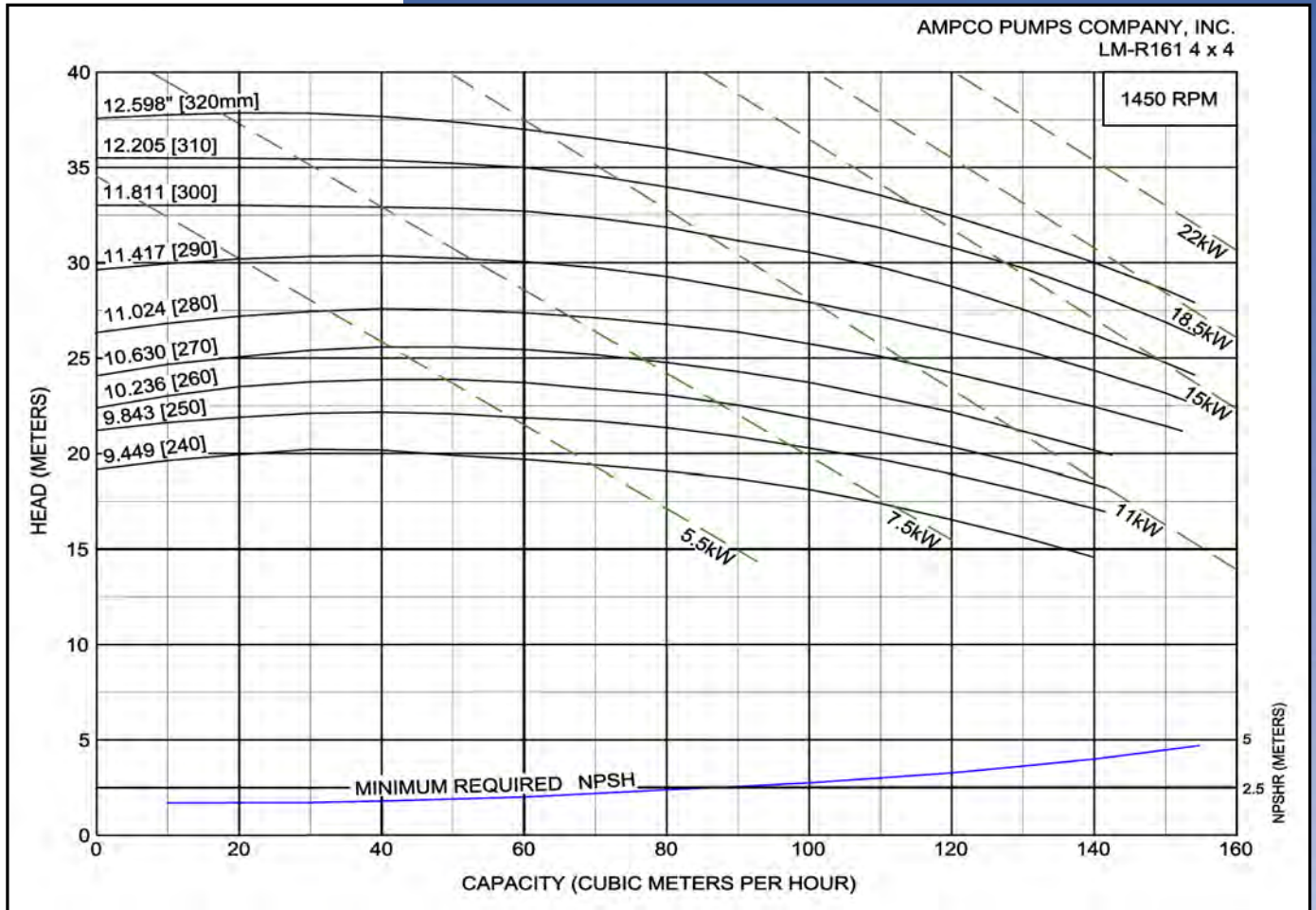

LM pumps are in conformance with 3A sanitary standards for centrifugal and positive rotary pumps for milk and milk products, Number 02-10.

LM-Series pumps have a standard 0.8µm (micrometers) finish, on all product contact surfaces.

AmpcoPumps Company

2045 West Mill Road-Glendale, Wisconsin 53209-PHONE (414) 643-1852-FAX (414) 643-4452

LM-X161 100X100 1/11