

ParaWeld Plate Heat Exchangers

WELDED PAIR PLATE HEAT EXCHANGER FOR REFRIGERATION



SPX offers an extensive portfolio of plate heat exchanges covering many industrial applications. Regularly SPX heat exchangers replace older technology products due to the simplicity of installation and their high performance thermal characteristics. Whether recovering waste heat or isolating the cooling system from the cooling source, SPX has the application knowledge and product to improve efficiency and performance.

Our vision for the future is rooted in a long standing tradition of excellence and commitment to progress. We strive to offer the customer the highest quality products and services today, tomorrow and beyond.

SPX provides advanced APV heat transfer solutions for cooling, heating, condensing and evaporation of process fluids - designed to solve heat transfer process challenges in a vast array of industries. They are designed to meet demanding process conditions and to optimize the utilisation of energy. APV heat transfer solutions have proven reliable and highly efficient helping customers worldwide to run their processes safely and economically. Dedicated and specialized SPX staff around the world is committed to design and provide efficient and durable heat transfer solutions to help customers optimize energy utilization and minimize downtime for improved profitability.

Proven Technology

It was Dr. Richard Seligman, APV's founder, who created the first commercially successful plate and frame heat exchanger in 1923. Since then APV Paraflow Plate Heat Exchangers are in successful operation in a variety of applications for the food, dairy, beverage, pharmaceutical, chemical, industrial, HVAC, and power markets. In addition, APV Paraflow plate heat exchangers are widely accepted in the industrial refrigeration market.

Components of the energy intensive refrigeration cycle are changing rapidly to maximize the commercial payback and thermal efficiency. For over 20 years, APV has fulfilled this need with the efficiency of our ParaWeld Plate Heat Exchangers, having proven reliability and high performance as both evaporators and liquid cooled condensers.

FLOODED EVAPORATION

A flooded evaporator has liquid refrigerant fed into the APV ParaWeld Plate Evaporator. The heat from the fluid being cooled causes the refrigerant to boil in the heat exchanger. In most cases, the basic system uses gravity to feed the refrigerant from a separator vessel and the differences in density of the two phase refrigerant causes it to flow through the heat exchanger and return to the separator. This is referred to as a natural recirculation or thermosyphon system.

The APV ParaWeld Plate Condenser cools and condenses the high pressure superheated vapor back to a liquid.

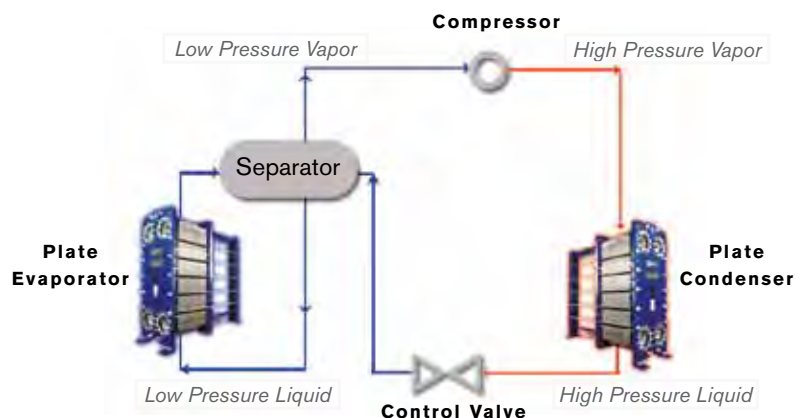

DIRECT EXPANSION EVAPORATION

In a direct or dry expansion system the refrigerant is fed directly to the APV ParaWeld plate heat exchanger without the use of a separator. Although theoretically a dry expansion evaporator may have a lower coefficient of performance, one can normally compensate for this by adjusting the heat transfer area and thus keep the system design simple with a significantly lower physical height.

The choice between such a system and the flooded system is driven by economics and technological suitability, except where a particularly close temperature approach rules out dry expansion. The dry expansion system is nearly always lower cost if a properly designed technology could be employed. A vast majority of current ParaWeld plate heat exchanger installations are flooded although use of dry expansion is increasing with the arrival of newer more reliable technology.

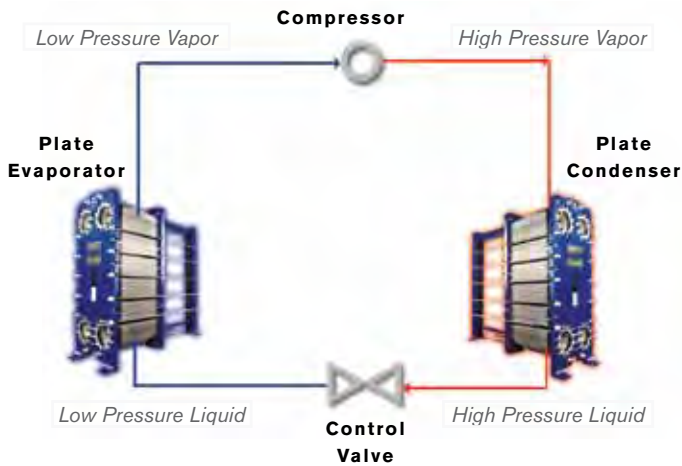

Typical Refrigeration Applications

APV ParaWeld Plate Heat Exchangers are used in a number of different refrigeration applications. They can function as:

Flooded Evaporators



Direct Expansion Evaporators

Liquid Cooled Condensers

Economizers



Desuperheaters

Subcoolers

Oil coolers

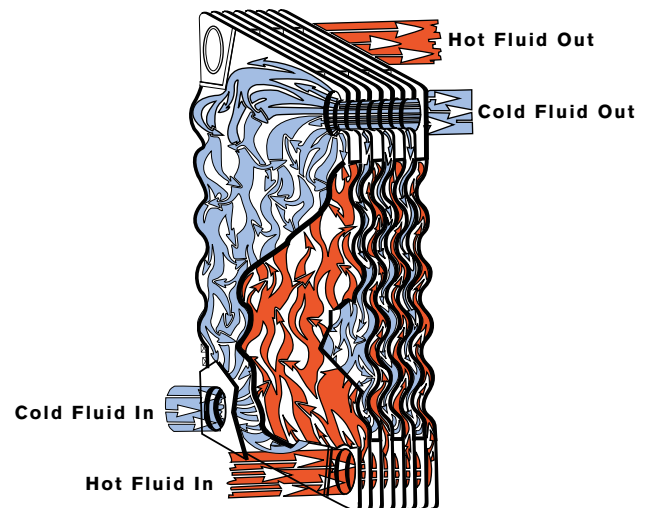

Typical LR4 Flooded Evaporator

ParaWeld Series Plate Heat Exchanger

MAXIMUM PERFORMANCE, MINIMAL SPACE AND LOW VOLUME HOLDUP.

The heat transfer plates are the heart of the APV ParaWeld heat exchanger providing reliability, efficiency and economy of operation. These plates are stamped in a corrugated design pattern to induce turbulent flow, then laser welded together in pairs at the flow perimeter, minimizing liquid bypass at the edges via a patented plate design system. The refrigerant flows through this welded plate channel and the fluid to be cooled is in the gasketed channel. The only gasketing in contact with the refrigerant are the circular port rings at the plate entrance and exit. Since the plates are welded pairs, the heat exchanger can easily be expanded should your duty requirements change in the future. Simply add more plate pairs to increase the refrigeration tonnage. The plates are pressed and laser welded in our Goldsboro, NC, USA facility. APV stocks 304ss, 316ss and titanium plate materials for faster delivery of new units and/or for spare parts.

Plates are also available in other alloys such as high nickel, super austenitic steels, etc, if required.

Gasket materials include neoprene and a selection of NBR's and EPDM's. FDA compliant gaskets are also available for certain direct product chilling duties.

Welded pairs are aligned in a rigid, polyurethane painted carbon steel frame through the use of a top carrying bar and bottom guide bar as illustrated in figure 7. Plates have an integral hanging eye to facilitate installation and maintain proper plate alignment and support within the frame.

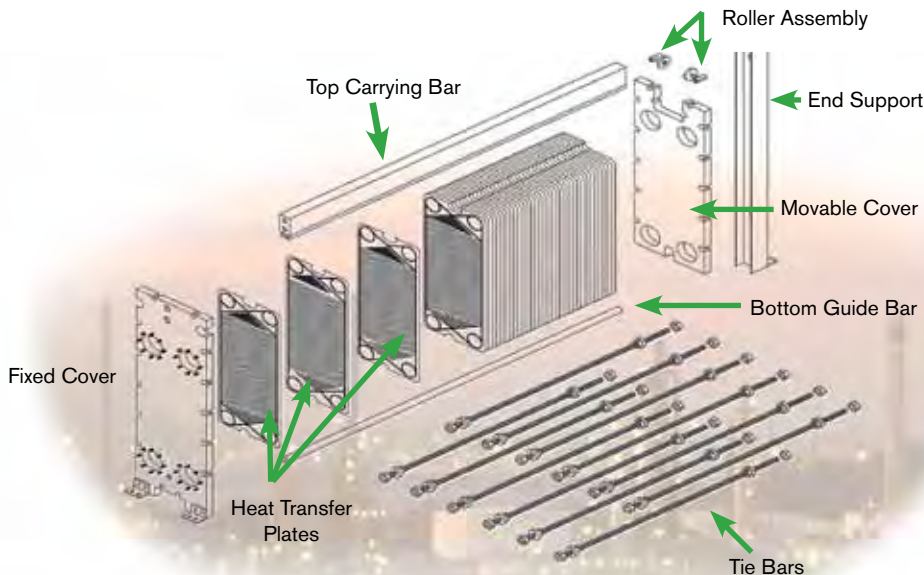
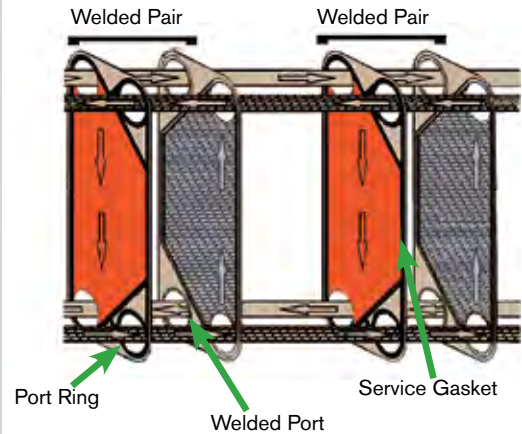
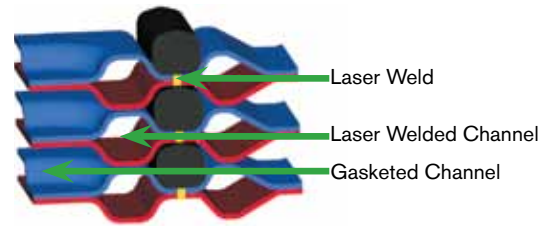
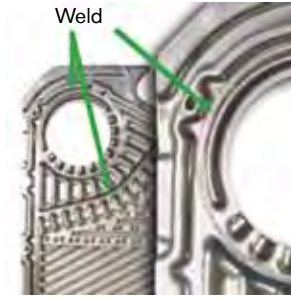

Tri-Flash™ DX Series

OFFERS STABLE PROCESS CONTROL THROUGH UNIFORM FEED DISTRIBUTION

The unique patented APV Tri-Flash™ DX series Plate Evaporator is specifically designed for the direct expansion “DX” refrigeration market. For successful “DX” evaporation the two phase feed must be evenly distributed between all parallel channels in the plate pack of the heat exchanger.

The Tri-Flash™ plate feed system is integral to the heat transfer plate port to ensure a uniform feed distribution to all plate passages and to promote optimum heat transfer efficiency. Proper feed distribution prevents liquid bypass, provides better process control and improves cooling performance. The APV “DX” series design provides a more equal feed distribution as compared to the use of a distribution tube in the feed port of the heat exchanger.

The APV Tri-Flash™ Plate Evaporator advantages include:

- Eliminates the need to employ an internal distribution tube of questionable performance.
- Provides protection from the possibility of liquid bypass which could desuperheat the outlet vapor.
- Provides excellent film distribution even at low feed rates.
- Plates can easily be added without the need for replacement or complex modification of the feed distribution system.
- Even flow distribution horizontally in the liquid phase across the plate pack.
- Total vaporization in each heat transfer channel for optimum performance.

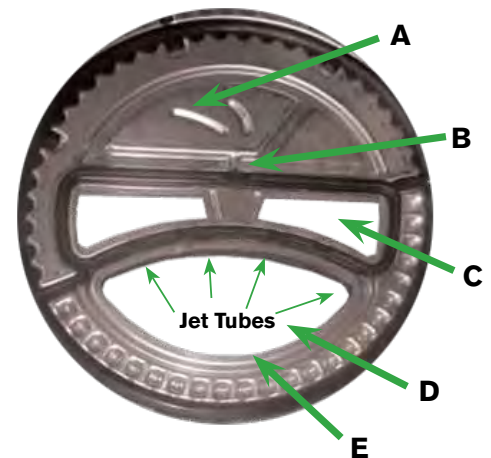

- A Third and final flash integral to welded pair refrigerant is turned laterally into flow passage.
- B Second flash transfer port into plate pair
- C Transfer port allows redistribution laterally down the port
- D Feed port ring (inside welded pair) contains up to four integral feed jet tubes (first flash)
- E Refrigerant feed from the expansion valve enters the primary port of the heat exchanger

APV ParaWeld Plate Heat Exchanger Versus Tubular Exchangers

WHY THE APV PARAWELD PROVIDES MORE FOR YOUR INVESTMENT

Flexibility

The ParaWeld Plate Heat Exchanger allows for future expansion when your refrigeration requirements grow. Semi-welded plate pairs can easily be added to the existing heat exchanger frame.

Saves Energy

The ParaWeld Plate Heat Exchanger provides approach temperatures as close as 2oF which allows for a higher suction temperature and higher coefficient of performance than a traditional shell and tube exchanger. This will help reduce compressor size and related components of a new refrigeration system.

Less Refrigerant Needed

The higher heat transfer coefficient significantly reduces the heat transfer area needed and the narrow plate passages have a low liquid holdup. The amount of refrigerant needed in a ParaWeld Plate Heat Exchanger is only 20-30% of the capacity compared to a tubular unit. Less refrigerant means more savings on the system charge and is better for the environment.

Models

The ParaWeld Plate Heat exchanger is available in models that range in connection size from 2" to 16". A single unit can handle up to 6,400 tons of refrigeration (5,806 metric tons).

Smaller Installed Space, Easy to Maintain

ParaWeld Plate Heat Exchangers use one third less floor space and weigh 1/6th the weight of a tubular heat exchanger. The APV Plate Heat Exchanger can be maintained within the installed space and without the need to remove piping.

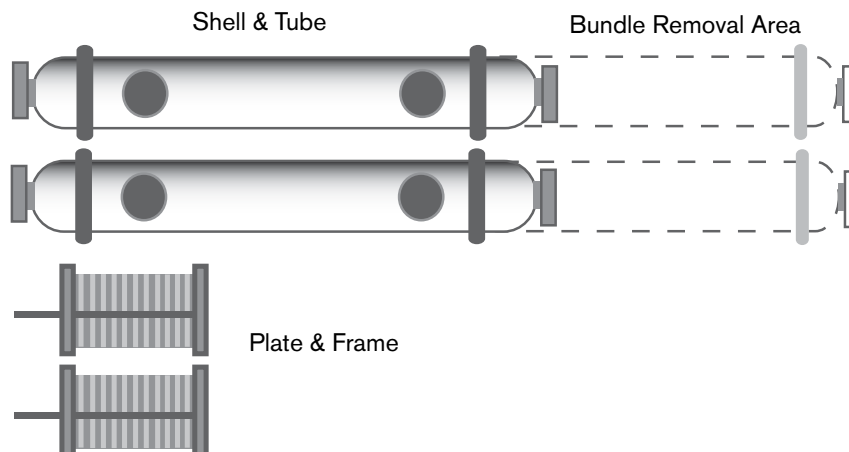

Dimensions

MODEL	CONNECTION SIZE in / mm	MAXIMUM LIQUID FLOW GPM m ³ /hr	MAXIMUM LENGTH in / mm	MAXIMUM WIDTH in / mm	MAXIMUM HEIGHT in / mm	MAXIMUM HEAT TRANSFER AREA ft ² / m ²	MAXIMUM REFRIGERATION* TONS (METRIC TONS)
LR2, LX2	2 50.8	250 57	67 1702	16 406	42 1067	677 63	115 104
LR4	4 101.6	800 182	81 2057	23 584	59 1499	1223 114	400 363
L039LES	6 150	1700 400	131 3318	24 608	62 1584	2982 277	650 590
L080LES	6 150	1700 400	131 3318	24 608	92 2340	6082 565	850 770
LR9GN, LX9GN	8 203.2	3100 704	126 3200	32 813	85 2159	5023 467	900 816
LR9AV, LX9AV	8 203.2	3100 704	126 3200	32 813	102 2591	5725 532	1400 1270
LR9AL	8 203.2	3100 704	126 3200	32 813	119 3023	7025 653	1900 1724
B063L	12 304.8	7000 1590	210 5334	39 991	81 2057	6110 568	2000 1814
B110L	12 304.8	7000 1590	210 5334	39 991	93 2362	10632 988	3100 2812
B134L	12 304.8	7000 1590	210 5334	39 991	109 2769	12877 1196	4200 3810
B158L	12 304.8	7000 1590	210 5334	39 991	119 3023	15035 1397	5300 4808
B205L	12 304.8	7000 1590	210 5334	39 991	138 3w505	19382 1801	6400 5806
Z155LDF	16 400	11500 2600	256 6500	51 1300	106 2700	11840 1100	3000 2720
Z195LDF	16 400	11500 2600	256 6500	51 1300	118 3000	13993 1300	4000 3630
Z230LDF	16 400	11500 2600	256 6500	51 1300	130 3300	17222 1600	5000 4540



APV ParaWeld Plate Heat Exchangers

WELDED PAIR PLATE
HEAT EXCHANGER FOR
REFRIGERATION



Installations

APV ParaWeld Plate Heat Exchanger installed as an evaporator as part of flooded ammonia refrigeration packaged system.



ABOUT SPX

Based in Charlotte, North Carolina, SPX Corporation (NYSE: SPW) is a global Fortune 500 multi- industry manufacturing leader. For more information, please visit www.spx.com

SPX FLOW TECHNOLOGY

105 CrossPoint Parkway

Getzville, NY 14068

P: (800) 462-6893

F: (716) 692-1715

E: answers.us@spx.com

SPX reserves the right to incorporate our latest design and material changes without notice or obligation.

Design features, materials of construction and dimensional data, as described in this bulletin, are provided for your information only and should not be relied upon unless confirmed in writing. Please contact your local sales representative for product availability in your region. For more information visit www.spx.com.

The green ">" is a trademark of SPX Corporation, Inc.

ISSUED 05/2013 1206-01-11-2009-US

COPYRIGHT © 2013 SPX Corporation